

HBJ4

4 Ton Multi-Purpose Hydraulic Jack

Assembly & Operating Instructions



READ ALL INSTRUCTIONS AND WARNINGS BEFORE USING THIS PRODUCT.

This manual provides important information on proper operation and maintenance. Every effort has been made to ensure the accuracy of this manual. We reserve the right to change this product at any time without prior notice.

STOP! DO NOT RETURN THIS PRODUCT TO THE RETAILER.

Questions? Problems? CONTACT BUFFALO TOOLS.

If you experience a problem or need parts for this product, visit our website <http://www.buffalotools.com> or call our customer help line at **1-800-568-6657, Monday-Friday, 8 AM - 4 PM Central Time**. A copy of the sales receipt is required.

Verify that you have received the parts in the correct quantities as shown below.



1. Release Valve Lever
2. Base
3. O-Ring
4. Hydraulic Cylinder
5. Ram
6. Hydraulic Oil
7. Oil Tight Tank
8. Extension Screw
9. Top Cap
10. Pump Plunger
11. Pump Body
12. O-Ring

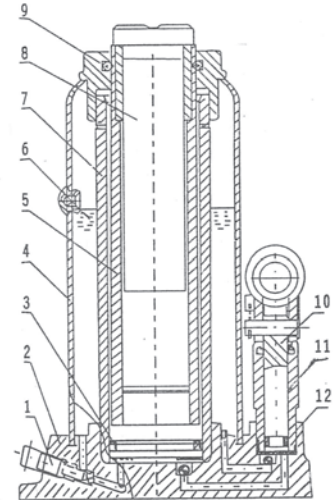

Parts List

Item No.	Description	Qty
1A	Hydraulic Jack	1
2B	Pump Handle	2

Minimum Height = 7.75"
Maximum Height = 12.75"

1. Before operating, estimate the weight of the load. **DO NOT OVERLOAD** the jack beyond its rated load.
2. Select point of action according to the gravitational center. Place the jack on a hard, flat surface.
3. Insert the notched end of the handle into the release valve. Turn the operating handle clockwise until release valve is closed. Do not overtighten the valve.
4. Insert pump handle into the socket and pump up and down slowly. The ram will raise and then stop when the required height is reached.
5. Lower the ram by slowly turning the release valve counter clockwise.

To Add or Replace Oil: Push RAM down fully. Remove rubber plug from reservoir and fill oil to plug position. Use motor oil S.A.E. 10W.

Warning

Use jack for lifting only. Never exceed this jack's rated load capacity. Never work under the lift load without additional support devices.