

# GENSD7

## 7000 Surge Watts / 5500 Running Watts DIESEL GENERATOR INSTRUCTION MANUAL



### **READ ALL INSTRUCTIONS AND WARNINGS BEFORE USING THIS PRODUCT.**

This manual provides important information on proper operation & maintenance. Every effort has been made to ensure the accuracy of this manual. These instructions are not meant to cover every possible condition and situation that may occur. We reserve the right to change this product at any time without prior notice.

**IF THERE IS ANY QUESTION ABOUT A CONDITION BEING SAFE OR UNSAFE,  
DO NOT OPERATE THIS PRODUCT!**

**DO NOT RETURN THIS PRODUCT TO THE RETAILER - CONTACT CUSTOMER SERVICE.**

If you experience a problem, have questions or need parts for this product, visit our website at <http://www.proseriesbrand.com>, or call Customer Service at 1-866-460-9436, Monday-Friday, 8 AM - 4 PM Central Time. A copy of the sales receipt is required.

**FOR CONSUMER USE ONLY – NOT FOR PROFESSIONAL USE.**

**KEEP THIS MANUAL, SALES RECEIPT & APPLICABLE WARRANTY FOR FUTURE REFERENCE.**

**⚠ DANGER**

**SEEK THE ADVICE OF A LICENSED ELECTRICIAN FOR 120V / 240V WIRING**

# GENSD7 7000 Surge Watts / 5500 Running Watts Diesel Generator



## FEATURES

- Generator Type : 7000 Surge Watt Diesel Fuel Only
- Self Excited, 2 Pole, Single Phase
- Voltage Regulator: Automatic (AVR)
- Starting System: Electric Start
- Engine Displacement: 418CC
- Engine Horsepower: 9 HP
- Fuel Type: Diesel
- Fuel Tank Capacity: 4 Gallons
- Engine Run Time: 7 Hours @ Full Load
- Engine Noise Level: <70 db
- Automatic Low Oil Shutdown
- Includes Wheels For Mobility
- EPA Approved

## TECHNICAL SPECIFICATIONS

Rated Frequency 60 Hz	Power Factor 1.0
Rated Voltage / AMP	120V / 20 A
Rated Voltage / AMP	120V / 25 A Twist Lock
Rated Voltage / AMP	240V / 30 A Twist Lock
Max Output 7.0 kw	Rated Output 5.5 kw
Phase - Single	
Max Height Above Sea Level	3,280 FT (1000 m)
Max Environment Temp	104°F (40°C)
Weight	396 Lbs (180 kg)
Oil Requirements	58 ounces 15W-40 Diesel Grade

Battery: Max. 7 3/4" L x 5 1/4" H x 7 1/4" W, 360 Min CCA (Cold Cranking Amps)

Comparable brands/models are Husky GT-X or Interstate: SP-35. These are not the only brands compatible with this generator. Any brand with similar specs may be used. The battery may be smaller in size, and have a higher CCA.

**Add Diesel Fuel ONLY (DO NOT ADD GASOLINE). DO NOT OVER FILL.  
DO NOT MODIFY THE GENERATOR. MODIFICATION WILL VOID ANY WARRANTIES.**

# TABLE OF CONTENTS

RECOGNIZE SAFETY SYMBOLS, WORDS AND LABELS .....	4
PACKAGE CONTENTS	
PACKAGE CONTENTS.....	9
COMPONENTS.....	9
PREPARING THE GENERATOR FOR USE	
Add Oil /Check Oil Level .....	10
Add Diesel Fuel ./ Check Fuel Level .....	10
Ground The Generator.....	11
Install Battery .....	11
STARTING THE GENERATOR.....	11
USING THE GENERATOR	
AC Usage .....	12
DC Usage .....	13
STOPPING THE GENERATOR .....	14
MAINTENANCE/CARE	
Recommended Maintenance Schedule.....	14
Cleaning The Generator .....	14
Checking The Oil Level .....	15
Changing/Adding Oil.....	15
Air Filter Maintenance.....	16
Emptying The Fuel Tank .....	16
Storage/ Transport.....	16
Replacing The Carbon Brushes .....	17
TROUBLESHOOTING.....	17

## THIS ENGINE MEETS U.S. EPA EMISSION STANDARDS UNDER 40 CFR 1054.625 .

The emission-related warranty is valid for two (2) years. Keep the purchase receipt and mail in the product registration card for proof of purchase. NB Corp limits emission-related warranty repairs to authorized service centers for owners located within 100 miles of an authorized service center. For owners located more than 100 miles from an authorized service center, NB Corp will, in its sole discretion, either pay for shipping costs to and from an authorized service center, provide for a service technician to come to the owner to make the warranty repair, or pay for the repair to be made at a local non-authorized service center. The provisions of this paragraph apply only for the contiguous states, excluding the states with high-altitude areas identified in 40 CFR part 1068, Appendix III.

To exercise this warranty, DO NOT RETURN TO RETAILER. Instead, call Customer Service toll free at 1-866-460-9436 (email address [info@buffalotools.com](mailto:info@buffalotools.com)) and you will be instructed on where to take the engine for warranty service. Take the generator and proof of purchase (your receipt) to the repair facility recommended by the Customer Service Representative. The warranty does not extend to generators damaged or affected by fuel contamination, accidents, neglect, misuse, unauthorized alterations, use in an application for which the product was not designed and any other modifications or abuse.

## 1 YEAR LIMITED WARRANTY (30 Day Limited Warranty for Commercial and Rental Purpose)

Generators are warranted to be free from defects in materials and workmanship for a period of 1 year from date of original purchase. NB Corp. is not liable for any indirect, incidental or consequential damages from the sale or use of this product. Any implied warranties are limited to 1 year as stated, or as otherwise stated, in this written limited warranty. Some states do not allow the exclusion or limitation of incidental or consequential damages. Some states do not allow limitation on the length of an implied warranty. NB Corp will repair or replace, at its discretion, any part that is proven to be defective in materials or workmanship under normal use during the 1 year warranty period. Warranty repairs or replacements will be made without charge for parts or labor. Parts replaced during warranty repairs will be considered as part of the original product and will have the same warranty period as the original product.

This warranty gives you specific legal rights, and you may have other rights that vary from state to state.

# RECOGNIZE SAFETY SYMBOLS, WORDS AND LABELS

## What You Need to Know About Safety Instructions

Warning and Important Safety Instructions appearing in this manual are not meant to cover all possible conditions and situations that may occur. Common sense, caution and care must be exercised when operating or cleaning tools and equipment.

Always contact your dealer, distributor, service agent or manufacturer about problems or conditions you do not understand.



This is the safety alert symbol. It is used to alert you to potential personal injury hazards. Obey all safety messages that follow this symbol to avoid possible injury or death.



DANGER indicates an imminently hazardous situation which, if not avoided, will result in death or serious injury.



WARNING indicates a potentially hazardous situation which, if not avoided, could result in death or serious injury.



CAUTION indicates a potentially hazardous situation which, if not avoided, may result in minor or moderate injury.



CAUTION used without the safety alert symbol indicates a potentially hazardous situation which, if not avoided, may result in property damage.

### **Add Diesel Fuel ONLY (DO NOT ADD GASOLINE)**

#### **Notice Regarding Emissions:**

Engines certified to comply with California and U.S. EPA emission regulations for SORE (Small Off Road Equipment) are certified to operate on regular unleaded gasoline and may include the following emission control systems: Three-Way Catalyst (TWC) (if equipped), and Engine Modifications (EM).

#### **Legal Requirements:**

Federal and/or State Occupational Safety and Health Administration (OSHA) regulations, local codes, and/or ordinances may apply to the intended use of this generator. Consult a qualified electrician, electrical inspector, and/or the local agency having jurisdiction. Some areas require generators to be registered with local utility companies. Additional regulations may apply if this generator will be used at a construction site.



**USE THIS GENERATOR ONLY OUTDOORS IN NON-CONFINED AREAS. DO NOT SECURE THE GENERATOR WITH A CHAIN OR ROPE, AS THIS WILL MAKE IT DIFFICULT TO MOVE IN AN EMERGENCY.**

## IMPORTANT SAFETY INSTRUCTIONS

# STOP!

Before using this generator and if you have any questions regarding the hazard and safety notices listed in this manual and/or on this generator, call 1-866-460-9436, Monday - Friday, 8 AM - 4 PM Central Time.

### DANGER

**Carbon Monoxide Gas:** When in operation, the exhaust from this generator contains poisonous carbon monoxide gas. Carbon monoxide gas is both odorless and colorless AND may be present even if you do not see or smell gas. Breathing this poison gas can lead to headaches, dizziness, drowsiness, loss of consciousness and eventually death.

- USE THIS GENERATOR ONLY OUTDOORS IN NON-CONFINED AREAS. DO NOT SECURE THE GENERATOR WITH A CHAIN OR ROPE, AS THIS WILL MAKE IT DIFFICULT TO MOVE IN AN EMERGENCY.
- Keep at least several feet of clearance on all sides to allow proper ventilation for this generator.

### WARNING

**Chemicals:** According to the State of California, the exhaust from this generator contains chemicals known to cause cancer, birth defects, or other reproductive harm.

### WARNING

**Flammable Fuel:** This generator may emit highly flammable and explosive fuel vapors, which can cause severe burns or even death. A nearby open flame can lead to an explosion even if not directly in contact with fuel.

- Do not operate this generator near open flame.
- Do not smoke near this generator.
- Always operate this generator on a firm, level surface.

**Diesel Fuel is highly flammable and explosive. Handling fuel can result in serious injury or burns.**

- Always shut down this generator before refueling. Refuel in a well-ventilated area. Keep heat, sparks and flame away while refueling and away from the location where diesel fuel is stored. Never refuel indoors where diesel fuel fumes may reach flames and/or sparks.
- Allow this generator to cool for at least 2 minutes before removing the fuel tank cap. Loosen the cap slowly to relieve pressure in the fuel tank. Avoid spilling fuel.
- Do not fill the fuel tank above the upper limit line. Diesel fuel may expand during operation. Do not fill to the top of the tank.
- Always check for spilled diesel fuel and immediately wipe it up before starting this generator.
- Empty the fuel tank before storing or transporting this generator.
- Always handle fuel outdoors.
- Before transporting, turn the fuel valve to the "OFF" position.

### DANGER

**Powerful Voltage:** This generator produces powerful voltage, which can result in electrocution.

- ALWAYS ground this generator before using it. (See "Ground the Generator" section in this manual).
- Only electrical devices should be plugged into this generator, either directly or with an extension cord. NEVER connect a building electrical system to this generator without a qualified electrician. **Doing so voids your warranty.** Such connections must isolate generator power from utility power and comply with local electrical laws and codes. Failure to comply can create a back feed into utility lines creating an electrocution hazard, which may result in serious injury or death to utility workers. Such a back feed may cause this generator to explode, burn and create fires when utility power is restored.
- Use a ground fault circuit interrupter (GFCI) in highly conductive areas such as metal decking or steel work. GFCIs are available in-line with some extension cords.
- Do not use this generator in wet conditions (rain, snow, active sprinkler system, wet hands, etc.). Always keep this generator dry and operate it with dry hands.
- Do not touch bare wires or outlets (receptacles).
- Do not allow children or non-qualified persons to operate this generator.

**⚠ DANGER**

**High Temperatures:** This generator produces heat when in operation. Temperatures near the exhaust can exceed 150 Degrees Fahrenheit (65 Degrees Celsius).

- Do not touch hot surfaces. Observe all warning placards on this generator denoting hot surfaces.
- Allow this generator to cool for several minutes after use before touching the engine, muffler or other areas that are hot during operation and before storing indoors.
- Hot exhaust may ignite some materials. Keep flammable materials away from this generator.
- Keep at least several feet of clearance on all sides of this generator during operation. Do not enclose this generator in any structure.

**⚠ CAUTION**

**Usage:** Misuse of this generator can damage it or shorten its life.

- Use this generator only for its intended purpose.
- Operate this generator only on a dry, level surface. Do not secure the generator with a chain or rope, which would prevent it from being moved in an emergency.
- Allow this generator to run for several minutes before connecting any electrical devices.
- Promptly turn off any malfunctioning devices and disconnect them.
- Do not operate an excessive number of electrical devices in excess of the wattage capacity of this generator.
- Do not turn on electrical devices until *after* they are connected to this generator.
- Turn off all connected electrical devices before stopping this generator.

**⚠ CAUTION**

**Usage:** Prolonged exposure to high noise levels can be hazardous to hearing. Always wear ANSI-approved hearing protection when operating or working around the generator when it is running.

**CAUTION**

**Usage:** This generator is not intended to power sensitive electronic equipment such as TVs, DVD players, stereos, desktop computers or laptop computers without the use of an appropriate line conditioner and/or surge protector (both not included). Sensitive electronic equipment should be operated on approved inverter type generators or pure sine wave generators. For additional information consult the devices operation manual or call customer service at 1-866-460-9436 Monday - Friday, 8 AM - 4 PM Central Time.

**⚠ WARNING**

**Usage:** Avoid the use of extension cords if possible. If you choose to use them, be sure they are sized adequately to handle the flow of electricity. An undersized cord can overheat, short out and cause a fire.

**⚠ CAUTION**

**Usage:** Do not use fuel stabilizers with this generator, doing so could cause damage to the generator, or decrease the fuel and operating efficiency of the generator. You may choose to add a fuel conditioner to oxygenate the fuel and to help it run more efficiently.

**⚠ WARNING**

**USE THIS GENERATOR ONLY OUTDOORS IN NON-CONFINED AREAS. DO NOT SECURE THE GENERATOR WITH A CHAIN OR ROPE, AS THIS WILL MAKE IT DIFFICULT TO MOVE IN AN EMERGENCY.**

## **WARNING**

*The engine exhaust from this product contains chemicals known to the State of California to cause cancer, birth defects or other reproductive harm.*

## **DANGER**

*EXHAUST CONTAINS POISONOUS CARBON MONOXIDE GAS THAT CAN BUILD UP TO DANGEROUS LEVELS IN CLOSED AREAS. BREATHING CARBON MONOXIDE CAN CAUSE UNCONSCIOUSNESS OR DEATH. Never run the generator in a closed or even partly closed area where people may be present.*

## **WARNING**

*GASOLINE IS HIGHLY FLAMMABLE AND EXPLOSIVE. YOU COULD BE BURNED OR SERIOUSLY INJURED IF THE GASOLINE IS IGNITED. Before refueling, stop the engine and keep heat, sparks and flame away. Handle fuel only outdoors. Do not fill the fuel tank above the upper limit line. Wipe up spills immediately.*

## **WARNING**

*IMPROPER CONNECTIONS TO A BUILDING CAN ALLOW ELECTRICAL CURRENT TO BACKFEED INTO UTILITY LINES, CREATING AN ELECTROCUTION HAZARD. Connections to a building must isolate generator power from utility power and comply with all applicable laws and electrical codes.*



In addition to the previously described safety information, familiarize yourself with all safety and hazard placards on this generator.

**⚠ DANGER POISONOUS GAS**

Generator exhaust contains toxic carbon monoxide gas. Breathing exhaust can cause loss of consciousness and shortness of breath. NEVER operate generator in poorly ventilated areas.

**⚠ WARNING**

Risk of electric shock. Do not remove cover. No user serviceable parts inside. Refer servicing to qualified service personnel.

**⚠ WARNING! RISK OF ELECTRIC SHOCK**

**This generator produces high voltage.**  
 Always ground properly before use.  
 Do not connect to any building electrical system.  
 Never use in rainy or wet conditions.  
 Never touch bare wires or receptacles.  
 Never allow children or non-qualified person to operate.



**⚠ CAUTION! HOT EXHAUST**

**⚠ DO NOT TOUCH**

**⚠ CAUTION! HIGH TEMPERATURE DO NOT TOUCH**

**⚠ DANGER**

Using a generator indoors CAN KILL YOU IN MINUTES. Generator exhaust contains carbon monoxide. This is a poison you cannot see or smell.

NEVER use inside a home or garage. EVEN IF doors and windows are open.	Only use OUTSIDE and far away from windows, doors, and vents.	



## PACKAGE CONTENTS

The following items are supplied with this Model GENSD7 7000 Surge Watts / 5500 Running Watts Portable Generator. Verify that all items are included.

# STOP!

If there are missing items, call 1-866-460-9436, Monday - Friday, 8 AM - 4 PM Central Time for customer service. **DO NOT RETURN THIS GENERATOR TO THE RETAILER.**

### Item List:

1 Each	240 Volt Twist Lock Outlet	1 Each	Fuel Filter
1 Each	120 Volt Twist Lock Outlet	1 Each	Air Filter
2 Each	120 Volt Outlet		
1 Each	Screwdriver	3 Each	Wrenches
1 Pair	Start Keys		
4 Each	Wheels		
1 Each	Oil Filter		

### **⚠ WARNING**

**USE THIS GENERATOR ONLY OUTDOORS IN NON-CONFINED AREAS. DO NOT SECURE THE GENERATOR WITH A CHAIN OR ROPE, AS THIS WILL MAKE IT DIFFICULT TO MOVE IN AN EMERGENCY.**

## GENERATOR COMPONENTS

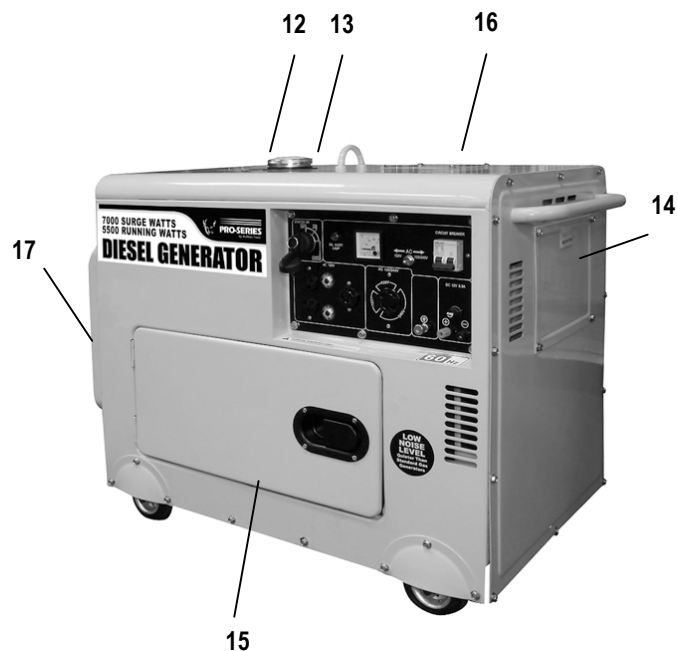
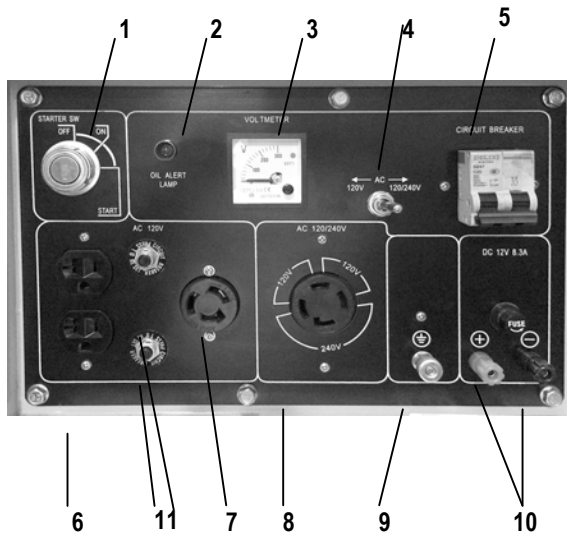

- |                          |                               |
|--------------------------|-------------------------------|
| 1) Electric Start Switch | 6) 120 Volt AC                |
| 2) Low Oil Alert         | 7) 120 V Twist Lock           |
| 3) Volt Meter            | 8) 120/240 Volt Twist Lock AC |
| 4) 120/240 Toggle Switch | 9) Ground                     |
| 5) Breaker               | 10) DC Terminal               |
|                          | 11) Reset                     |

- |                                                     |
|-----------------------------------------------------|
| 12 Fuel Gauge                                       |
| 13 Fuel Cap                                         |
| 14 Air Filter Panel Cover                           |
| 15 Engine Access Cover                              |
| 16 Access Panel to Decompression Relief Valve Lever |
| 17 Muffler Panel Cover                              |

# PREPARING THE GENERATOR FOR USE

## STOP!

The following section describes the required steps for preparing this generator for use. Failure to correctly perform these steps can damage this generator and/or shorten its life. If still unsure about how to perform any of these steps after reading this section, call 1-866-460-9436 Monday - Friday, 8 AM - 4 PM Central Time for customer service.

If this generator is being used for the first time, the following few steps are required to prepare it for operation:

### Step 1 - Add Oil, Then Add Diesel Fuel

This generator requires engine oil to function. Engine oil is a major factor affecting engine performance and service life. When new from the package, this generator contains no oil in the engine crankcase. The correct quantity of oil is equal to the oil capacity of the engine crankcase and is 58 fluid oz (1.8 quart) for this Model GENSD7 7000 Surge Watts / 5500 Running Watts Portable Generator. Add the correct quantity of oil before operating this generator for the first time.

<b>Model GENSD7 Oil Capacity (fluid oz./ Quart)</b>	58 ounces (1.8 quart)
<b>Model GENSD7 Oil Type Recommended</b>	SAE 15W-40 Diesel Grade Oil

To add oil:

1. Confirm that this generator is on a level surface.
2. Open the Oil Access Panel as illustrated in Figure 1 and Figure 2.
3. Using a funnel, add high detergent motor oil to fill the engine crankcase to the correct quantity as stated above. SAE 15W-40 Diesel Grade Oil is recommended. When the engine crankcase is full, the oil level should reach the lower lip of the oil fill opening.
4. Replace the oil filler/dipstick cap and close the oil access panel.

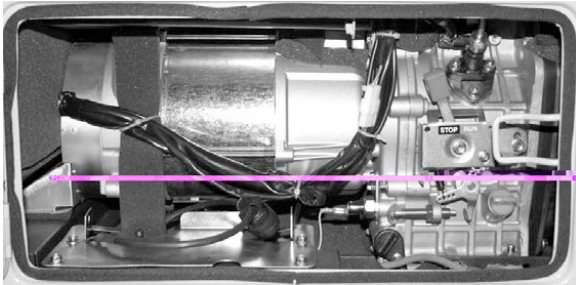

Figure 1 – Open the Engine Access Panel



Figure 2 – Close Up View

### **⚠ WARNING**

**Diesel Fuel and fumes are highly flammable and explosive. Handling fuel can result in serious injury or burns.**

• Do not fill the fuel tank near a heat, sparks or an open flame. Keep fuel away from appliance pilot lights, barbecues, electric appliances, power tools, etc. Do not overfill the fuel tank. Always check for fuel spills and immediately wipe them up. Spilled fuel is a fire hazard.

To add diesel fuel, use only FRESH, DIESEL FUEL:

1. Confirm that this generator is on a level surface.
2. Unscrew fuel tank cap and set aside. (NOTE: The fuel tank cap may be tight and difficult to unscrew.)
3. Slowly add fresh, diesel fuel to the fuel tank. Be careful not to fill the fuel tank above the upper limit line. The fuel tank capacity for this generator is 4 gallon (15 L). NOTE: Because diesel fuel can expand, do not fill the fuel tank to the very top.
4. Securely tighten the fuel tank cap and immediately wipe up any spilled fuel with a dry cloth.

<b>Model GENSD7 Fuel Tank Capacity (gals /L)</b>	4 Gallons / 15 Liters
<b>Model GENSD7 Fuel Type</b>	Diesel Fuel

## Step 2 - Ground the Generator



Failure to properly ground this generator can result in electrocution.

Ground this generator by tightening the grounding nut against a grounding wire (Figure 3), found on the front of the battery. A No. 12 AWG (American Wire Gauge) stranded copper wire is generally an acceptable grounding wire. The other end of this grounding wire should be connected to a copper or brass-grounding rod that is driven into the earth.

Grounding codes can vary by location. Contact a local electrician for information on grounding regulations for your area.



## Step 3 – Install Battery (Not included)

This generator requires a battery to start. The generator does not come equipped from the factory with a battery.

A 12 Volt motorcycle battery no larger than 7 3/4" L x 5 1/4" H x 7 1/4" W, with a 360 Minimum CCA (Cold Cranking Amps). Comparable brands/models are Husky: GT-X or Interstate: SP-35. These are not the only brands compatible with this generator. Any brand with similar specs may be used. The battery may be smaller in size, and have a higher CCA. **\*\*Brands/model numbers can change, this information is intended as a guide only, if your sparkplug needs to be replaced, please visit your local auto parts store for their recommendation, or call 1-866-460-9436 Monday - Friday, 8 AM - 4 PM Central Time for customer service for assistance\*\***

The battery case is located behind the metal plate under the electrical panel. Install the battery by using the two cables (one red and the other black) that were included in the packaging, or are attached to the generator.

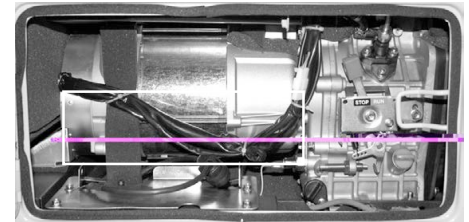

Step 3 Battery Location

**Disconnect all electrical loads from this generator before changing the battery.**

1. Attach the end of the red cable to the positive/red terminal on the battery.
2. Attach the end of the black cable to the negative/black terminal on the battery.
3. Bolt the battery to the battery plate.

## STARTING THE GENERATOR

# STOP!

**Before starting this generator, confirm that all the steps in the section titled, "Preparing the Generator for Use," of this manual have been correctly completed. If unsure about how to perform any of these steps, call 1-866-460-9436, Monday - Friday, 8 AM - 4 PM Central Time for customer service.**

If the generator has been used before, always check the oil level and diesel fuel level. Always check that the battery is secure and the generator has been grounded.

To start this generator:

1. Confirm that there are no electrical devices connected to this generator.
2. Confirm that this generator is properly grounded. (See "Ground the Generator")
3. 120V or 120V/240V is available at the same time.

Move the Toggle Switch left or right to the correct setting (Figure 6)

4. Move Circuit Breaker to OFF position. (Figure 6A)
5. Set the engine Run switch to the "Run" position (Figure 6B).
6. Insert Key and turn it to the start position. (Figure 6C).
7. If the engine fails to start, repeat step 6. NOTE: After repeated attempts, consult the Troubleshooting Guide before attempting again. (You may need to open top panel and push down on Decompression Lever.)

If problems persist, **call 1-866-460-9436, Monday - Friday, 8 AM - 4 PM Central Time.**

8. Allow this generator to run for several minutes before connecting any electrical devices.
9. Move Circuit Breaker to ON position.
10. Connect electrical devices.

**Fuel Cock** The fuel cock is located between the fuel tank and carburetor. When the fuel cock is in the ON position, fuel is allowed to flow from the fuel tank to the carburetor. Be sure to return the fuel cock to the OFF position after stopping the engine.

Figure 6A

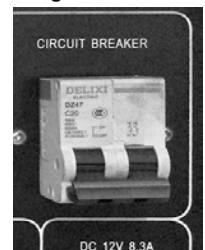

Figure 6B

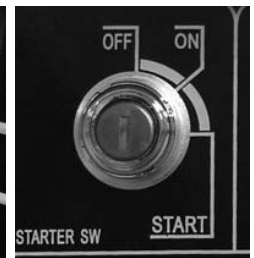

Figure 6C

## USING THE GENERATOR

### **CAUTION**

Connect only electrical devices that are in good working order. Faulty devices or power cords present the risk of electrical shock. Immediately turn off and disconnect any device that commences to operate abnormally, sluggish or abruptly stops. Determine if the problem was the device or the rated load capacity of this generator has been exceeded.

### **WARNING**

- USE THIS GENERATOR ONLY OUTDOORS IN NON-CONFINED AREAS. DO NOT SECURE THE GENERATOR WITH A CHAIN OR ROPE, AS THIS WILL MAKE IT DIFFICULT TO MOVE IN AN EMERGENCY.
- Keep at least several feet of clearance on all sides to allow proper ventilation for this generator.

After the engine has been running for several minutes, electrical devices may be connected to this generator.

**WARNING:** Altering the fuel controller will VOID the warranty. Do not alter the fuel controller. (Figure A).



(Fig A)

## AC Usage

Electrical devices running on AC current may be connected according to their wattage requirements. The rated (running) and surge wattage for this Model GENSD7 7000 Surge Watts / 5500 Running Watts Portable Generator is 6,300 and 7,000 respectively.

The *rated (running) wattage* corresponds to the maximum wattage a generator can output on a continuous basis.

The *surge wattage* corresponds to the maximum amount of power a generator can output for a short time. Many electrical devices, such as a refrigerator, require short bursts of extra power for starting and stopping fan motors, etc., in addition to their listed rated wattage. Motorized devices typically require more than their rated wattage for startup. The surge wattage ability of a generator allows for this extra power requirement.

The total running wattage requirement of the electrical devices connected to a generator should not exceed the rated wattage of the generator itself. To calculate the total wattage requirement of the electrical devices to be connected, look up the rated (running) wattage of each device and add these numbers together to find the total wattage that all of the devices together will draw from the generator. If the total wattage of the selected devices exceeds the rated wattage of the generator, DO NOT connect all of the devices. Select a combination of the electrical devices that will have a total wattage less than or equal to the rated wattage for the generator.

### **CAUTION**

This generator can run at its surge wattage capacity for only a short time. Connect electrical devices requiring a rated (running) wattage equal to or less than the rated wattage of this generator. Never connect devices requiring a rated wattage equal to the surge wattage of a generator.

Electrical Device	Rated (Running) Watts	Additional Surge Watts
air compressor (1 - 1/2 HP)	2500	2500
airless sprayer (1/3 HP)	600	1200
coffee maker	1500	0
computer w/17 inch monitor	800	0
deep freezer	500	500
electric drill (1/2 HP)	1000	1000
furnace fan blower (1/2 HP)	800	1300
hot plate	2500	0
microwave oven (1000 watt)	1000	0
quartz halogen work light	1000	0
refrigerator/freezer (18 Cu. Ft.)	800	1600
saw - circular (7 1/4 inch)	1500	1500
stereo receiver	450	0
electric stove - single element	1500	0
sump pump	800	1200
television (27 inch color)	500	0
well water pump (1/3 HP)	1000	2000
window air conditioner (10000 BTU)	1200	1800
window fan	300	600

A device's rated (running) wattage should be listed somewhere on the device itself and/or in its manual. If the wattage specification for a device is not available, the wattage can be calculated by multiplying the Voltage requirement (120 or 240) by the Amperage drawn.

Or, the wattage required by a device can be estimated by using the following chart. The chart provides only estimates and it is better to know the exact wattage of each electrical device to be powered by this generator.

$$\text{Watts} = \text{Volts} \times \text{Amperes}$$

Connect electrical devices to this generator according to the following procedure:

Allow the engine to run for several minutes after it has been started.

Confirm that the electrical device is switched off prior to plugging it into this generator.

**NOTE:** Plug appliances into the correct outlet. Connect standard 120 Volt, single phase, 60 Hz loads to the 120 Volt outlet. Connect 12 Volt, DC loads to the 12 Volt outlet.

**⚠ CAUTION**

Even though this generator has an overall rated wattage of 7000, do not attempt to draw more than 5500 Watts from the 120 Volt and/or 240 Volt outlet. Draws higher than 5500 Watts will damage this generator and void the warranty.

**NOTE:** While this generator is running, power is available from either the standard 120 Volt outlet or the 12 Volt DC outlet. Both 120 Volts and 12 Volts can be simultaneously drawn from this generator.

Turn on the connected electrical devices beginning with the device with the highest rated wattage requirement and then each additional device with the next lower rated wattage requirement.

**⚠ CAUTION**

Do not connect 50Hz or 3-phase loads to this generator.

## DC Usage

**⚠ CAUTION**

The DC terminal is only for recharging 12 Volt automotive-type batteries. Do not connect any other device to this outlet.

**⚠ CAUTION**

Use this generator only for recharging 12 Volt batteries. NEVER attempt to jumpstart a car with this generator.

**⚠ DANGER**

Failing to use the correct procedure can cause a battery to explode, seriously injuring anyone nearby. Keep heat, sparks, flame and smoking materials away from the battery.

To connect 12 Volt batteries to the DC outlet:

1. Connect one charging wire to the positive terminal of the battery and the other charging wire to the negative terminal of the battery.
2. Connect the free end of the positive wire to the positive side of the outlet on this generator.
3. Carefully connect the free end of the negative wire to the negative side of the outlet on this generator.
4. Start this generator.
5. When disconnecting, always disconnect the wires from this generator first to avoid a spark.

**⚠ DANGER**

**Storage batteries emit highly explosive hydrogen gas when charged.**

**Batteries also contain acid, which can cause severe chemical burns.**

- Do not allow open flames or cigarettes nearby for several minutes after charging a battery.
- Always wear protective goggles and rubber gloves when charging a battery.
  - If battery acid gets on the skin, flush with water.
  - If battery acid gets in the eyes, flush with water and immediately call a physician.
  - If battery acid is swallowed, drink large quantities of milk and immediately call a physician.

**⚠ DANGER**

Do not secure the generator with a chain or rope, which would prevent it from being moved in an emergency.



# STOPPING THE GENERATOR

To stop this generator:

1. Turn off all connected electrical devices and then unplug them.
2. Switch the circuit breaker to the "OFF" position. (Figure 10)
3. Allow this generator to run for several more minutes with no electrical temperature of this generator.
4. Set the engine Run lever to the "Stop" position. (Figure 11)
5. Turn the Starter switch to Off Position. (Figure 12).

Figure 10



Figure 11



Figure 12



## **⚠ WARNING**

Allow this generator to cool down before touching areas that become hot during operation.

## **⚠ CAUTION**

Allowing diesel fuel to sit in this generator's fuel tank for extended time without use can increase the difficulty in starting this generator in the future. Never store this generator for extended time with fuel in the fuel tank.

# MAINTENANCE/CARE

Proper routine maintenance of this generator is essential for safe, economical, and trouble-free operation. It will help prolong the life of this generator as well as help reduce air pollution. Perform maintenance checks and procedures according to the schedule in Figure 7.

## **⚠ CAUTION**

Never perform maintenance procedures while this generator is running. Allow this generator to cool before commencing any maintenance procedures. Keep heat, sparks and flame away.

## **⚠ WARNING**

Improper maintenance and/or failure to correct any problems prior to operating this generator can cause a malfunction which could cause death or serious injury. Always follow the inspection and maintenance recommendations and schedules in this manual.

## Recommended Maintenance Schedule

		Each Use	Every Month or Each 20 Hrs	Every 3 Months or Each 50 Hrs	Every 6 Months or Each 100 Hrs	Every Year or Each 300 Hrs
Engine Oil	Check Level	X				
	Replace		X (First Use)		X	
Air Filter	Check	X				
	Clean			X		
Fuel Filter	Replace					X
Oil Filter	Replace					X
Fuel Tank	Verify Gas Level	X				
	Clean					X

Figure 7 - Recommended maintenance schedule

## Cleaning the Generator

Always use this generator in a cool dry place. If the generator becomes dirty, the exterior can be cleaned with a damp cloth.

Never clean this generator with a bucket of water and/or a hose as water can get inside and cause a short circuit or corrosion. Never use gasoline to clean parts of this generator.

## Replacing Oil Filter

Replace oil filter every year or 300 hours.

Oil Filter

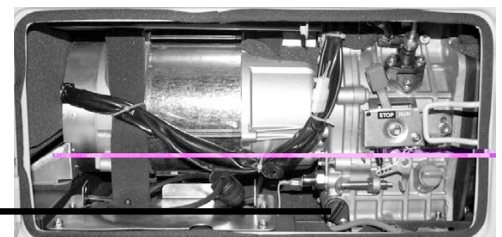

## Checking the Oil Level

It is important to check the oil level in the engine crankcase before each use to ensure that there is a sufficient quantity.

To check the oil level:

1. Verify that this generator is shut down and on a level surface.
2. Unscrew the oil filler/dipstick cap from the engine.
3. With a dry cloth, wipe the oil off of the dipstick that is located on the inside of the cap.
4. Insert the dipstick as if replacing the cap and then remove again. There should be oil on the dipstick. If there is no oil on the dipstick, or oil is visible only at the very end of the dipstick, add oil until the engine crankcase is filled.
5. Confirm that the oil filler/dipstick cap is properly in place when finished verifying the oil level.

## Changing/Adding Oil

The oil level in this generator should be checked before each use. (See Figure 8.) When the oil level is low, add oil until the level is sufficient to operate this generator.

The oil capacity for this Model GENSD7 7000 Surge Watts / 5500 Running Watts Portable Generator engine is 58 fluid oz. (1.8 quart).

To drain the oil from this generator:

The oil should be changed after the first 20 hours of operation. The oil should then be changed every 6 months, or for every 100 hours of use time, or when it has become contaminated with water and/or dirt.

1. Place a tray underneath this generator to catch oil as it drains.
2. Unscrew the oil drain plug located on the crankcase underneath the oil filler/dipstick cap.
3. Allow all the oil to drain from this generator.
4. Replace the oil drain plug and tighten.

**NOTE: Never dispose of used motor oil in the trash, down a drain or on the ground. Put oil in a sealed container and contact your local recycling center or auto garage to arrange oil disposal.**

To add oil to the engine crankcase:

1. Confirm that this generator is on a level surface.
2. Unscrew the oil filler/dipstick cap from the engine as illustrated in Figure 8 below.
3. Using a funnel, add high detergent motor oil to fill the engine crankcase to the correct quantity. SAE 15W-40 Diesel Grade oil is recommended for general use. When the engine crankcase is full, the oil level should reach the lower lip of the oil filling opening.

<b>Oil Capacity (fluid oz./L)</b>	58 fluid ounces / 1.8 quart
<b>Oil Type Recommended</b>	SAE 15W-40 Diesel Grade Oil

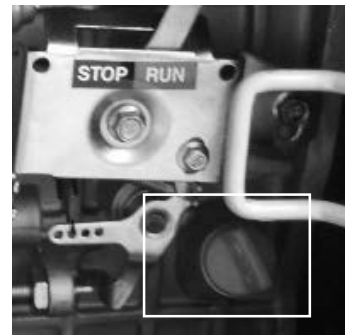
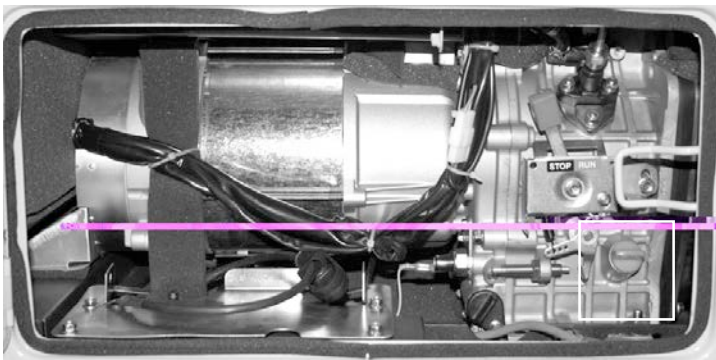

Figure 8



## Air Filter Maintenance ( Fuel Filter Maintenance)

Routine maintenance of the air filter helps maintain proper airflow to the carburetor. Occasionally verify that the air filter is free of excessive dirt. The air filter will require more frequent cleaning when operating this generator in extremely dusty areas.

To clean air filter, remove the access panel from side of generator, then remove wing nut to expose the element. (Figure 9)

Remove the foam filter element from the generator and wash it in warm water and household dish detergent. Thoroughly rinse and dry. Wring out the filter and reinstall in the generator.



Figure 9 – Changing The Air Filter



( Figure A – Change Fuel Filter located inside front access panel once a year )

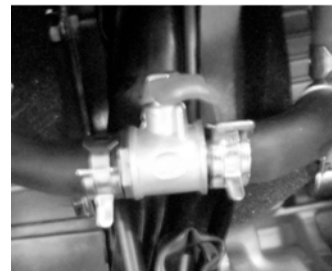

( Figure B – Fuel Valve)

## Emptying the Fuel Tank

To store this generator for extended time, drain the diesel fuel from the fuel tank. To drain fuel from this generator:

1. Turn the fuel valve to the “off” position.
2. Remove the inline fuel filter.
3. Place a funnel underneath the fuel valve to catch fuel as it drains into a bucket.
4. Turn the fuel valve to the “on” position and allow all fuel to drain. (Figure B)
5. Turn the fuel valve to the “off” position.
6. Replace the inline fuel filter.
7. Store the drained fuel in a suitable place.

To store this generator for extended time, the fuel needs to be drained from the carburetor.

To drain the gasoline from the carburetor turn the fuel valve to the “off” position while the engine is running. The generator will shut down when all the gasoline in the carburetor has been used.

## STORAGE/TRANSPORT PROCEDURES

### **CAUTION**

**Never place any type of storage cover on this generator while it is still hot.**

When transporting or storing this generator for extended time:

- Allow generator to fully cool before moving it. A hot engine and exhaust system can burn you and ignite some materials.
- Empty the fuel tank. (See “Emptying the Fuel Tank” in the “Maintenance/Care” section.)
- Turn the fuel valve to the “off” position.
- Do not obstruct any ventilation openings.
- Do not drop or strike this generator while moving it.
- Store this generator in a cool dry area, free of excessive dust.

Storage Time	Recommended Storage Procedure (which will help prevent difficult starts)
Less than 1 month	No storage procedure required.
1 to 2 months	Fill with fresh diesel fuel
2 months to 1 year	Empty the fuel tank. (See “Emptying the Fuel Tank” in the “Maintenance/Care” section.)
1 year or more	Empty the fuel tank. (See “Emptying the Fuel Tank” in the “Maintenance/Care” section.)

## Replacing The Carbon Brushes



1. Remove Muffer Access Panel

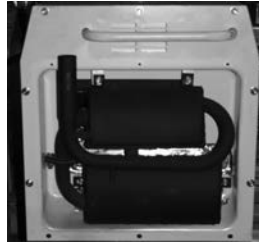

2. Remove Dual Muffer System



3. Remove Both Mufflers

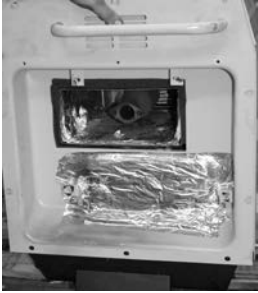

4. Remove End Panel



5. Brush Assembly is Visible



6. Locate Carbon Brushes



7. Replace Carbon Brushes

## TROUBLESHOOTING

**IMPORTANT:** If trouble persists, call our customer help line at **1-866-460-9436, Monday - Friday, 8 AM - 4 PM Central Time.**

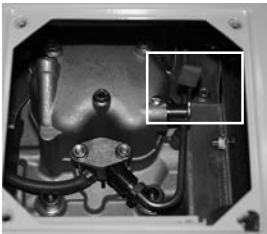
Symptom	Cause	Solution	
 <p>(Figure 8)</p>	Engine will not start.	Engine switch is set to "off."	
		Set engine switch to "on."	
		Engine is out of diesel fuel.	Add diesel fuel.
		Oil is low.	Add or replace oil.
		Generator is not on level surface.	Move generator to a level surface to prevent triggering the low oil shutdown.
		Spring loaded Decompression Lever has closed the exhaust valve.	Open top panel. (Figure 8) Push down on Decompression Lever, reinstall top panel. Start engine.
		Engine is filled with contaminated and/or old diesel fuel.	Drain fuel from the engine and add new diesel fuel.
Engine runs but there is no electrical output.	Circuit breaker is off.	Flip circuit breaker to "on."	
	Reset button is "off."	Push reset button to "on."	
	Bad connecting wires/cables.	Try a different extension cord.	
	Bad electrical device connected to generator.	Disconnect device, try connecting another device.	
	Loose wiring and/or connection behind control panel or at end of generator.	Tighten the nuts that secure the wiring.	
Carbon brushes or AVR are worn or broken.	See Figure B (page 27). Visually inspect to make sure they are in contact with the two copper bands on the rotor. Replace as necessary.		
Generator runs but does not support all connected electrical devices.	Generator is overloaded.	Reduce draw on generator to within this generator's rated wattage by reducing number of connected electrical devices.	
	Short in one of the connected devices.	Disconnect any faulty or short-circuited electrical loads.	
	Air filter is dirty.	Clean or replace air filter.	

# GENSD7 7000 SURGE WATTS / 5500 RUNNING WATTS DIESEL GENERATOR PARTS DIAGRAM

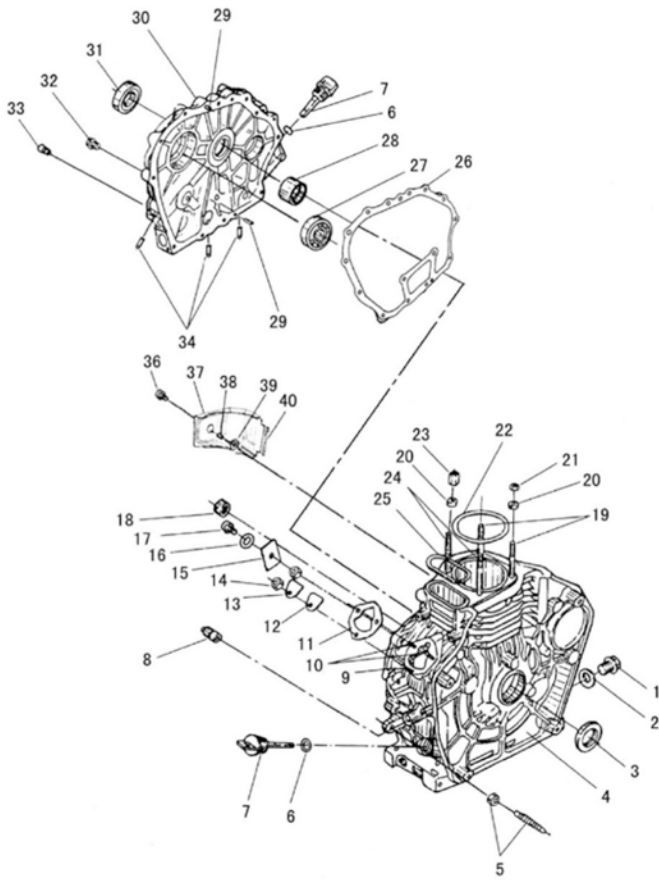

FIGA ENGINE BLOCK ASSEMBLY

REF. NO.	PART NO.	DESCRIPTION	Q'TY	REMARKS
1	DG-D186-A01	Drain plug	1	
2	DG-D186-A02	Oil Plug seal	1	
3	DG-D186-A03	Oil seal 35×50×10	1	
4	DG-D186-A04	Cylinder block	1	
	DG-D186-A04-E	Cylinder block	1	
5	DG-D186-A05	Fuel controller	1	
6	DG-D186-A06	O-ring 24×2.4	2	
7	DG-D186-A07	Oil depth gauge	2	
8	DG-D186-A08	Needle bearing 7941/8	2	7941/8
9	DG-D186-A09	Stud plate (short)	1	
10	DG-D186-A10	Stud plate (long)	2	
11	DG-D186-A11	Fuel injection pump gasket	1	
12	DG-D186-A12	Seal gasket	1	
13	DG-D186-A13	Seal plate	1	
14	DG-D186-A14	Nut M6	3	
15	DG-D186-A15	Retainer	1	
16	DG-D186-A16	Washer 8	1	
17	DG-D186-A17	Bolt M8×12	1	
18	DG-D186-A18	Needle bearing 37941/15	1	
19	DG-D186-A19	Cylinder head stud (short)	2	
20	DG-D186-A20	Cylinder head washer	4	
21	DG-D186-A21	Cylinder head nut (short)	2	
22	DG-D186-A22	Cylinder head gasket	1	
23	DG-D186-A23	Cylinder head nut (long)	2	
24	DG-D186-A24	Cylinder head stud (long)	2	
25	DG-D186-A25	Ring	1	
26	DG-D186-A26	Crank case gasket	1	
27	DG-D186-A27	Ball bearing D207	1	
28	DG-D186-A28	Main bearing	1	
29	DG-D186-A29	Pin 8×12	2	
30	DG-D186-A30	Crank case cover	1	
31	DG-D186-A31	Oil seal	1	
32	DG-D186-A32	Bolt M8×34	16	
33	DG-D186-A33	Plug	1	
34	DG-D186-A34	Plunger 8	3	
36	DG-D186-A36	Bolt M6×14	1	
37	DG-D186-A37	Air shroud	1	
38	DG-D186-A38	Air shroud collar	1	
39	DG-D186-A39	Shock absorber	1	
40	DG-D186-A40	Shock absorber seat	1	



41 DG-D186-A41 Oil pressure sensor 1

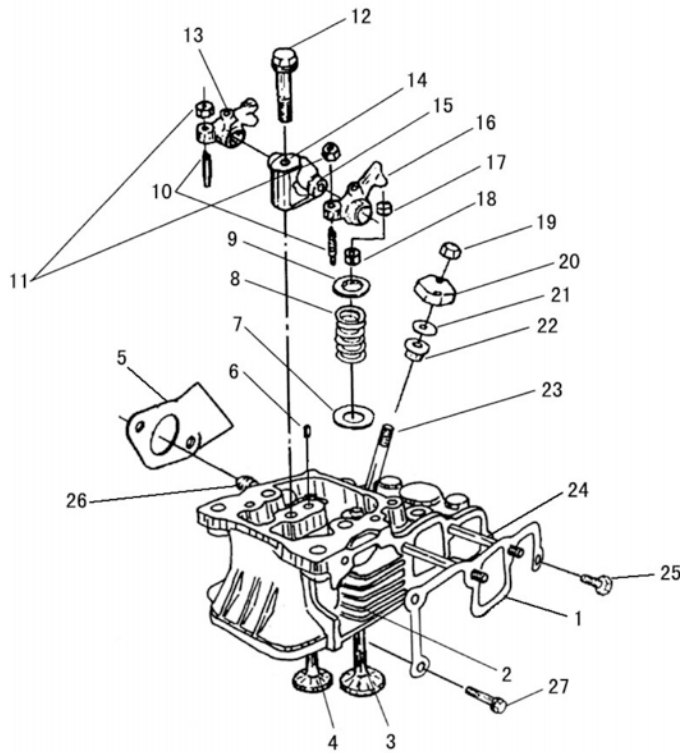

FIG.B CYLINDER HEAD ASSEMBLY

REF. NO.	PART NO.	DESCRIPTION	Q'TY	REMARKS
1	DG-D186-B01	Air intake gasket	1	
2	DG-D186-B02	Cylinder head	1	
3	DG-D186-B03	Intake valve	1	
4	DG-D186-B04	Exhaust valve	1	
5	DG-D186-B05	Silencer gasket	1	
6	DG-D186-B06	Pin 4×8	1	
7	DG-D186-B07	Valve spring washer	2	
8	DG-D186-B08	Valve spring	2	
9	DG-D186-B09	Spring retainer	2	
10	DG-D186-B10	Valve screw	2	
11	DG-D186-B11	Nut M6	2	M6
12	DG-D186-B12	Rocker arm bolt	1	
13	DG-D186-B13	Exhaust valve rocker arm	1	
14	DG-D186-B14	Rocker arm support	1	
15	DG-D186-B15	Rocker arm shaft	1	
16	DG-D186-B16	Intake valve rocker arm	1	
17	DG-D186-B17	Valve adjusting plate	2	
18	DG-D186-B18	Valve Keeper	4	
19	DG-D186-B19	Nut M6	2	M6
20	DG-D186-B20	Nozzle retainer	1	
21	DG-D186-B21	Spacer washer	1	
22	DG-D186-B22	Spacer	1	
23	DG-D186-B23	Stud M6×50	2	M6×50
24	DG-D186-B24	Stud M6×75	2	M6×75
25	DG-D186-B25	Bolt M6×22	2	M6×22
26	DG-D186-B26	Stud M8×20	2	M8×20
27	DG-D186-B27	Bolt M6×28	1	M6×28

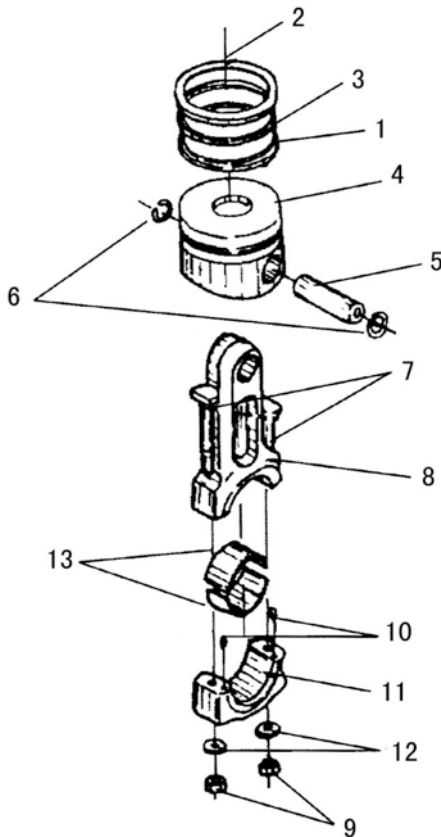

FIG.D PISTON, CONNECTING ROD ASSEMBLY

REF. NO.	PART NO.	DESCRIPTION	Q'TY	REMARKS
1	DG-D186-D01	Oil ring	1	
2	DG-D186-D02	First Piston Ring	1	
3	DG-D186-D03	Second Piston Ring	1	
4	DG-D186-D04	Piston	1	
5	DG-D186-D05	Piston pin	1	
6	DG-D186-D06	Washer 23	1	23
7	DG-D186-D07	Connecting rod body	1	
8	DG-D186-D08	Rod bolt	2	
9	DG-D186-D09	Rod nut	2	
10	DG-D186-D10	Pin 3×10	2	3×10
11	DG-D186-D11	Crank pin box	1	
12	DG-D186-D12	Rod bolt washer	2	
13	DG-D186-D13	Crank pin bearing	2	

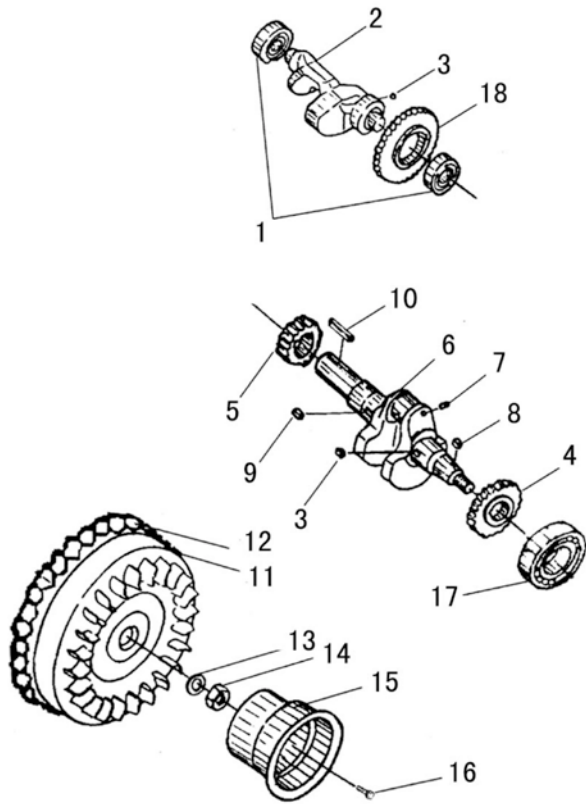

FIG. E CRANK SHAFT, FLYWHEEL ASSEMBLY

REF. NO.	PART NO.	DESCRIPTION	Q'TY	REMARKS
1	DG-D186-E01	Ball Bearing 6203	2	
2	DG-D186-E02	Balancer shaft	1	
3	DG-D186-E03	Key 5×7	2	5×7
4	DG-D186-E04	Balancer gear	1	
5	DG-D186-E05	Crank shaft timing gear	1	
6	DG-D186-E06	Crank shaft	1	
7	DG-D186-E07	Plunger 6	1	
8	DG-D186-E08	Key 5×12	1	5×12
9	DG-D186-E09	Key 5×14	1	5×14
10	DG-D186-E10	Key 6×50	1	6×50
11	DG-D186-E11	Flywheel	1	
12	DG-D186-E12	Flywheel gear	1	
13	DG-D186-E13	Flywheel nut washer	1	
14	DG-D186-E14	Flywheel nut	1	
15	DG-D186-E15	Starter pulley	1	
16	DG-D186-E16	Bolt M6×12	4	M6×12
17	DG-D186-E17	Ball Bearing 6308	1	
18	DG-D186-E18	Balancer gear	1	

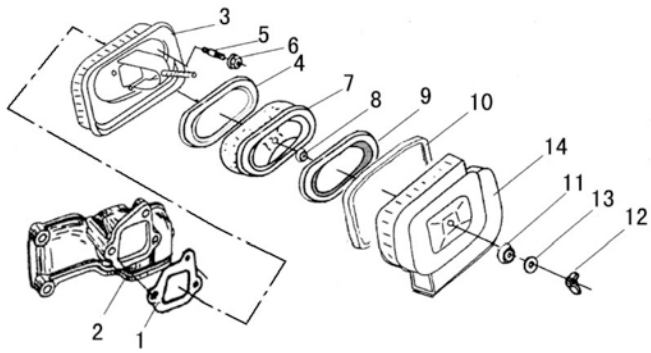
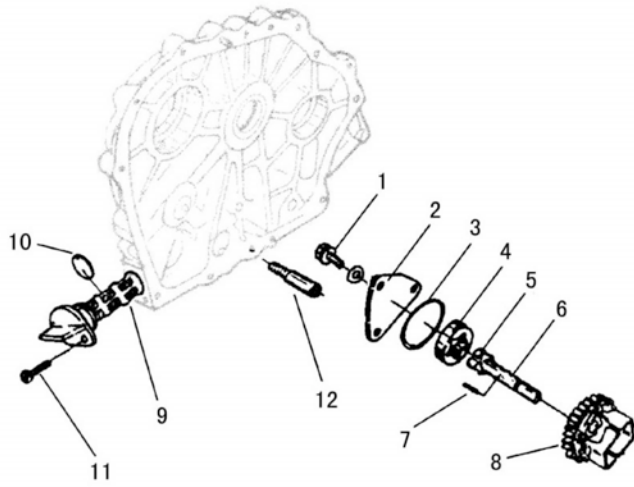

FIG.G AIR CLEANER ASSEMBLY

REF. NO.	PART NO.	DESCRIPTION	Q'TY	REMARKS
1	DG-D186-G01	Air cleaner gasket	1	
2	DG-D186-G02	Intake pipe	1	
3	DG-D186-G03	Air cleaner bottom case	1	
4	DG-D186-G04	Shock absorber washer B	1	B
5	DG-D186-G05	Air cleaner element bolt	1	
6	DG-D186-G06	Nut M6	3	M6
7	DG-D186-G07	Air cleaner element	1	
8	DG-D186-G08	Element shock absorber	1	
9	DG-D186-G09	Shock absorber washer A	1	A
10	DG-D186-G10	Ring	1	
11	DG-D186-G11	Air cleaner shock absorber	1	
12	DG-D186-G12	Nut M8	1	M8
13	DG-D186-G13	Washer 8	1	8
14	DG-D186-G14	Air cleaner cover	1	



FIGH LUBE OIL SYSTEM

REF. NO.	PART NO.	DESCRIPTION	Q'TY	REMARKS
1	DT-D186-H01	Bolt M6×8	3	M6×8
2	DT-D186-H02	Oil pump cover	1	
3	DT-D186-H03	O-ring 34.5×1.8	1	
4	DT-D186-H04	Outer rotator	1	
5	DT-D186-H05	Inner rotator	1	
6	DT-D186-H06	Oil pump shaft	1	
7	DT-D186-H07	Pin 3×16	1	3×16
8	DT-D186-H08	Oil pump gear	1	
9	DT-D186-H09	Oil filter	1	
10	DT-D186-H10	O-ring 25×2.4	1	
11	DT-D186-H11	Bolt M6×14	1	M6×14
12	DT-D186-H12	Intake pipe	1	

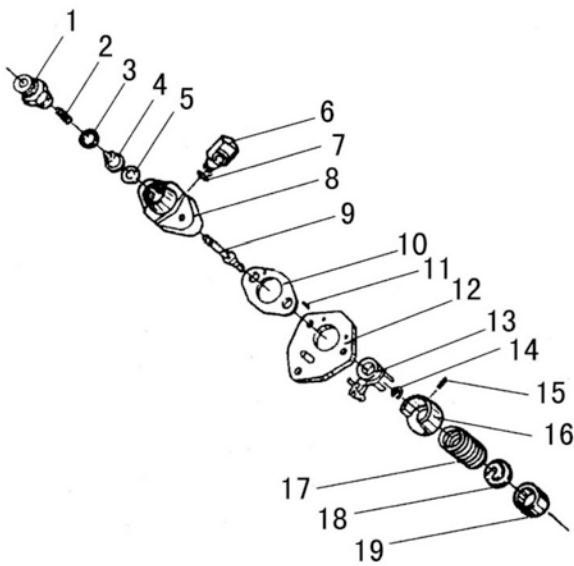

FIG.I FUEL INJECTION PUMP ASSEMBLY

REF. NO.	PART NO.	DESCRIPTION	Q'TY	REMARKS
1	DT-D186-I01	Delivery holder	1	
2	DT-D186-I02	Delivery spring	1	
3	DT-D186-I03	Delivery gasket	1	
4	DT-D186-I04	Delivery valve	1	
5	DT-D186-I05	Delivery seat	1	
6	DT-D186-I06	Joint	1	
7	DT-D186-I07	O-Ring	1	
8	DT-D186-I08	F.I. Pump body	1	
9	DT-D186-I09	Plunger	1	
10	DT-D186-I10	Shim set	1*	
11	DT-D186-I11	Pin 2×6	2	2×6
12	DT-D186-I12	Packing	1	
13	DT-D186-I13	Control lever	1	
14	DT-D186-I14	Snap ring	1	
15	DT-D186-I15	Pin 3×8	1	3×8
16	DT-D186-I16	Spring seat	2	
17	DT-D186-I17	F.I. Pump spring	1	
18	DT-D186-I18	Spring seat	1	
19	DT-D186-I19	Tappet	1	



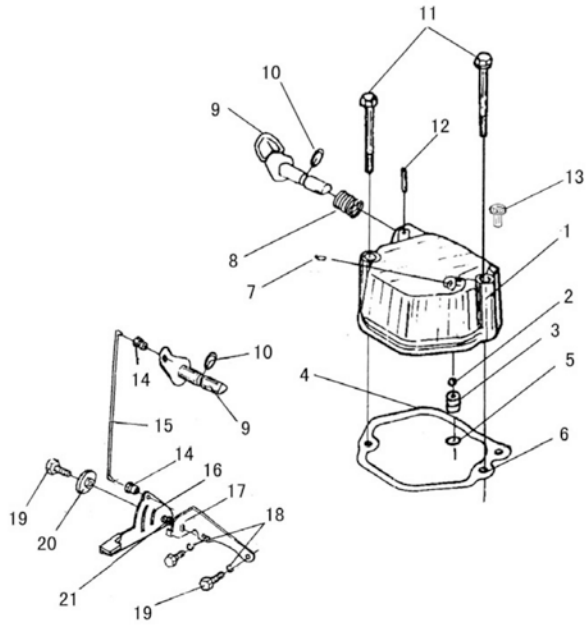

FIG.C VALVE COVER ASSEMBLY

REF. NO.	PART NO.	DESCRIPTION	QTY	REMARKS
1	DG-D186-C01	VALVE COVER	1	
2	DG-D186-C02	Ball	1	
3	DG-D186-C03	Breather	1	
4	DG-D186-C04	Pin	1	
5	DG-D186-C05	O-ring 12×1.9	1	
6	DG-D186-C06	Valve Cover	1	
7	DG-D186-C07	Plunger 8×10	1	8×10
8	DG-D186-C08	Decompression spring	1	
9	DG-D186-C09	Decompression shaft	1	
10	DG-D186-C10	O-ring 10×1.9	1	
11	DG-D186-C11	Bolt M6×70	2	M6×70
12	DG-D186-C12	Pin 3×16	1	3×16
13	DG-D186-C13	Plunger	1	
14	DG-D186-C14	Decompression wire collar	2	
15	DG-D186-C15	Decompression wire	1	
16	DG-D186-C16	Outer decompression handle	1	
17	DG-D186-C17	Decompression handle support	1	
18	DG-D186-C18	Washer 6	2	6
19	DG-D186-C19	Bolt M6×15	3	M6×15
20	DG-D186-C20	Decompression handle Bushing	2	
21	DG-D186-C21	Nut M6	1	M6

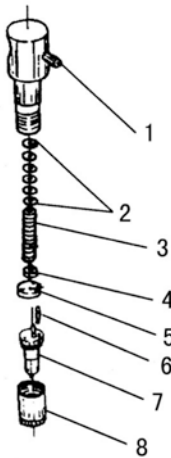

FIG.J FUEL INJECTOR ASSEMBLY

	PART NO.	DESCRIPTION	Q'TY	REMARKS
1	DG-D186-J01	Nozzle holder	1	
2	DG-D186-J02	Shim pack	1*	
3	DG-D186-J03	Nozzle holder spring	1	
4	DG-D186-J04	Spring retainer	1	
5	DG-D186-J05	Stop plate	1	
6	DG-D186-J06	Pin	2	
7	DG-D186-J07	Nozzle valve	1	
8	DG-D186-J08	Nozzle case nut	1	



FIGK GOVERNOR & CONTROL SYSTEM

REF. NO.	PART NO.	DESCRIPTION	Q'TY	REMARKS
1	DG-D186-K01	Control handle shaft	1	
2	DG-D186-K02	Governor handle shaft	2	
3	DG-D186-K03	Governor spring	1	
4	DG-D186-K04	Return spring	1	
5	DG-D186-K05	High speed limit screw	1	
6	DG-D186-K06	Nut M6	1	M6
7	DG-D186-K07	Bolt M6×14	1	M6×14
8	DG-D186-K08	Bolt M6×20	1	M6×20
9	DG-D186-K09	Nut M10×1.25	1	M10×1.25
10	DG-D186-K10	Bowl -shape cover	1	
11	DG-D186-K11	Spring	1	
12	DG-D186-K12	Handle bracket	1	
13	DG-D186-K13	Control handle	1	
14	DG-D186-K14	Governor lever welded part	1	
15	DG-D186-K15	Pin 3×22	2	3×22
16	DG-D186-K16	Lever fork	1	
17	DG-D186-K17	Lever shaft	1	
18	DG-D186-K18	Governor lever washer	3	
19	DG-D186-K19	Seal 2.6×14×8	1	
20	DG-D186-K20	Tappet	1	
21	DG-D186-K21	Fly block	2	
22	DG-D186-K22	Fly block pin	2	

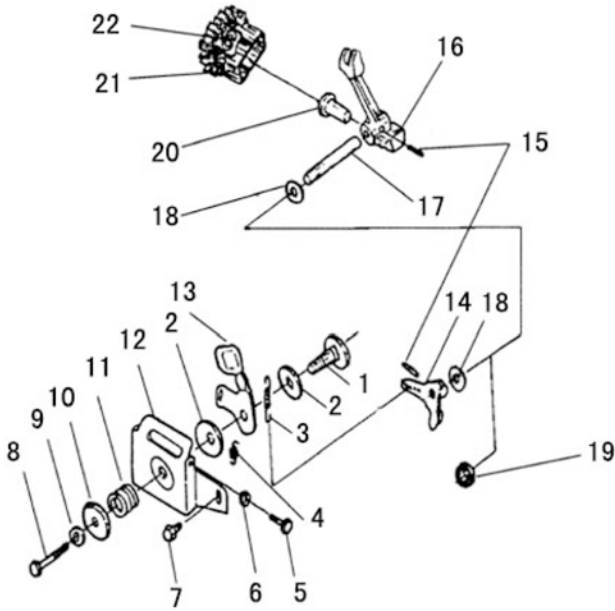

FIGL FLYWHEEL COVER ASSEMBLY

REF. NO.	PART NO.	DESCRIPTION	Q'TY	REMARKS
1	DG-D186-L01	Shock absorber seat	1	
2	DG-D186-L02	Flywheel cover	1	
3	DG-D186-L03	Shock absorber	4	
4	DG-D186-L04	Collar	4	10×10
5	DG-D186-L05	Washer 6	4	6
6	DG-D186-L06	Bolt M6×14	4	

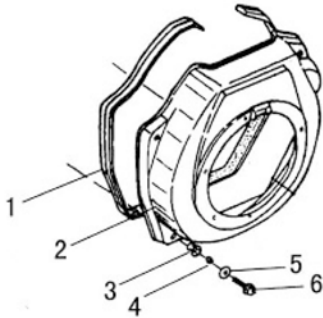

FIG.N MUFFLER

REF. NO.	PART NO.	DESCRIPTION	QTY
1	DG-D186-N01	Catalyst	1
2	DG-D186-N02	Gasket	1
3	DG-D186-N03	Bolt	2
4	DG-D186-N04	Muffler	2
5	DG-D186-N05	Nut	2
6	DG-D186-N06	Bolt	2

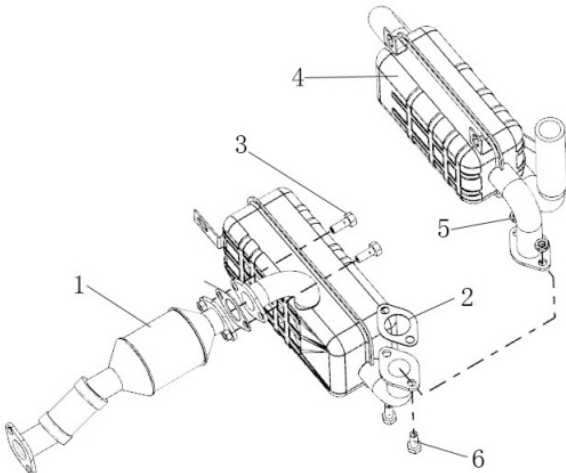
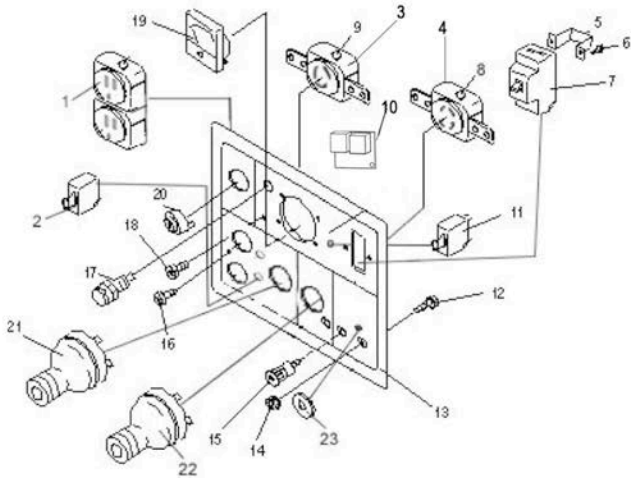

FIG R. CONTROL PANEL (HDY5000LX)

NO.	PART NO.	PART NAME	QTY	REMARKS
1	DGG-H500-R01-E	120 Volt AC	1	
2	DGG-H500-R02-E	Reset	2	
3	DGG-H500-R03-E	120V AC Twist Lock Socket	1	
4	DGG-H500-R04-E	120/240V AC Twist Lock Socket	1	
5	DGG-H500-R05-E	Clasp	1	
6	DGG-H500-R06-E	Screw M4×10	2	
7	DGG-H500-R07-E	AC circuit breaker	1	
8	DGG-H500-R08-E	Nut M4	4	
9	DGG-H500-R09-E	<b>Nut M4</b>	2	
10	DGG-H500-R10-E	Rectifier	1	
11	DGG-H500-R11-E	120/240 Toggle switch	1	
12	DGG-H500-R12-E	Fuse holder	1	
13	DGG-H500-R13-E	Control panel	1	
14	DGG-H500-RR14-E	DC output -	1	
15	DGG-H500-R15-E	DC output +	1	
16	DGG-H500-R16-E	Screw M4×10	4	
17	DGG-H500-R17-E	Oil warning light	1	
18	DGG-H500-R18-E	Screw M5×20	1	
19	DGG-H500-R19-E	Voltmeter	1	
20	DGG-H500-R20-E	Engine switch	1	
21	DGG-H500-R21-E	AC plug	1	
22	DGG-H500-R22-E	AC plug	1	
23	DGG-H500-R23-E	Fuse	1	



FIGF CAMSHAFT ASSEMBLY

REF. NO.	PART NO.	DESCRIPTION	Q'TY	REMARKS
1	DG-D186-F01	Push Rod	2	
2	DG-D186-F02	vaive tappet	2	
3	DG-D186-F03	Camshaft timing gear	1	
4	DG-D186-F04	Key 5×14	1	5×14
5	DG-D186-F05	Camshaft	1	

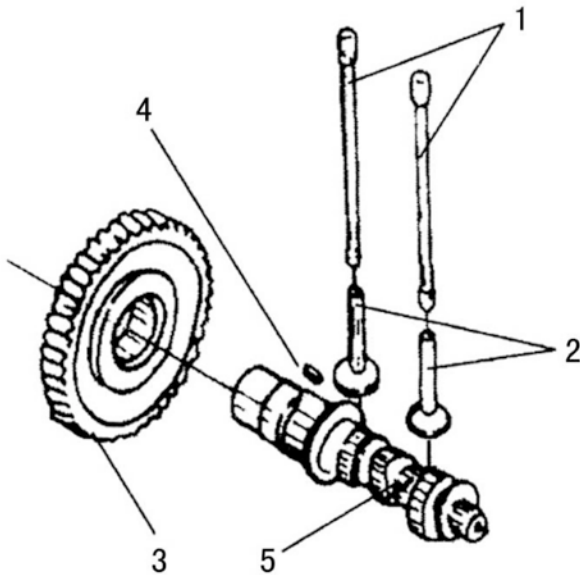

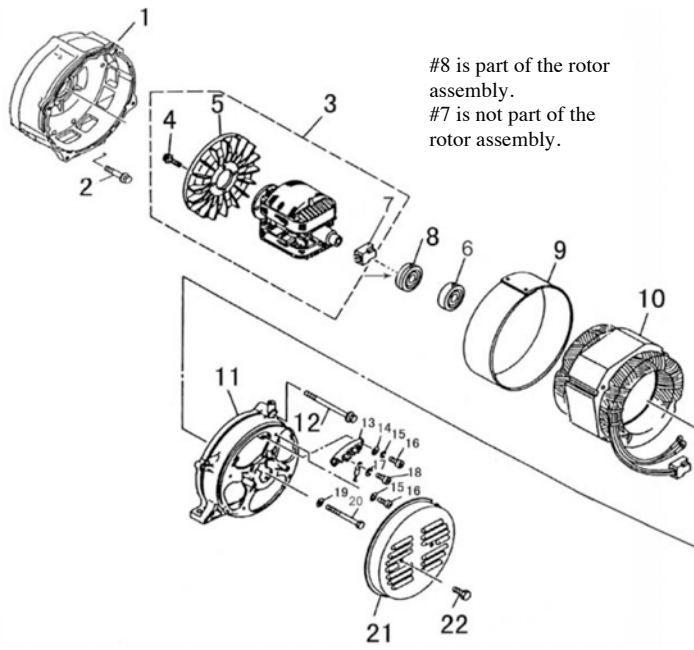

FIG P. GENERATOR

NO.	PART NO.	PART NAME	QTY	REMARKS
1	DGG-H500-P01	Front Cover	1	
2	DGG-H500-P02	Flange Bolt	4	M8x30
3	DGG-H500-P03	Rotor Assy	1	
4	DGG-H500-P04	Bolt	4	M6x16
5	DGG-H500-P05	Fan blade	1	
6	DGG-H500-P06	bearing	1	
7	DGG-H500-P07	Carbon Brush Set	1	
8	DGG-H500-P08	Collecting ring	1	
9	DGG-H500-P09	Stator cover	1	
10	DGG-H500-P10	Stator Assy	1	
11	DGG-H500-P11	Rear Cover	1	
12	DGG-H500-P12	Flange Bolt	4	M8x125
13	DGG-H500-P13	Plate	1	
14	DGG-H500-P14	Washer	2	6
15	DGG-H500-P15	Washer	2	6
16	DGG-H500-P16	Bolt	2	M6x16
17	DGG-H500-P17	Washer (copper)	8	6
18	DGG-H500-P18	Bolt (copper)	4	M6x16
19	DGG-H500-P19	Washer	1	
20	DGG-H500-P20	Bolt	1	M10x250x1.25
21	DGG-H500-P21	End Cover	1	
22	DGG-H500-P22	Bolt M6 × 10	2	M6x10

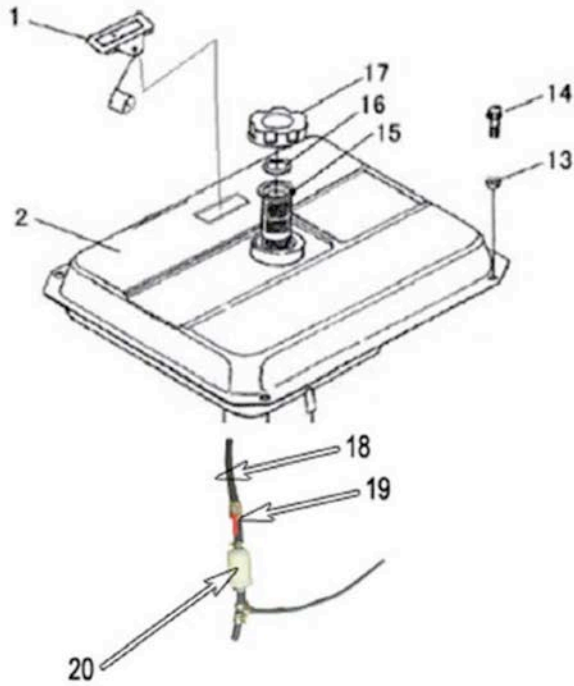
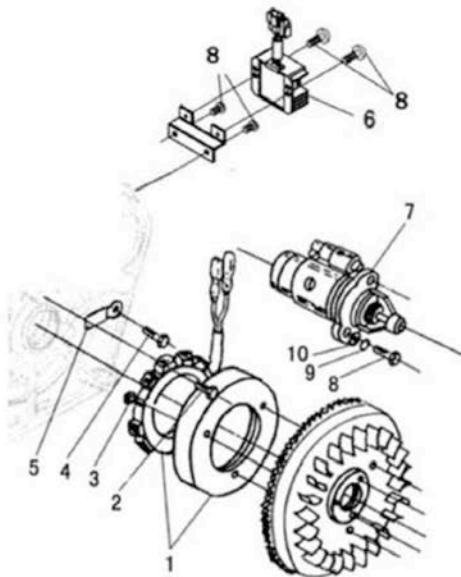

FIG. M FUEL TANK & FUEL PIPE ASSEMBLY

REF. NO.	PART NO.	DESCRIPTION	QTY
1	DG-D186-M01	Fuel level gauge	1
2	DG-D186-M02	Fuel tank	1
13	DG-D186-M13	Fuel tank damper	4
14	DG-D186-M14	Bolt M6×30	4
15	DG-D186-M15	Fuel oil filter	1
16	DG-D186-M16	Fuel lever mark	1
17	DG-D186-M17	Fuel tank cap	1
18	DG-D186-M18	FUEL OIL RETURN PIPE	1
19	DG-D186-M19	FUEL VALVE	1
20	DG-D186-M20	FUEL FILTER	1



FIGO STARTING MOTOR

REF. NO.	PART NO.	DESCRIPTION	QTY	REMARKS
1	DG-D186-O01-E	Flywheel generator	1	
2	DG-D186-O02-E	Bolt M6×30	3	M6×30
3	DG-D186-O03-E	Screw M6×12	3	M6×12
4	DG-D186-O04-E	Bolt M6×12	3	M6×12
5	DG-D186-O05-E	Clamp	1	
6	DG-D186-O06-E	Regulator	1	
7	DG-D186-O07-E	Starting motor	1	
8	DG-D186-O08-E	Bolt M10×35	6	M10×35
9	DG-D186-O09-E	Washer 10	2	10
10	DG-D186-O10-E	Washer 10	2	10

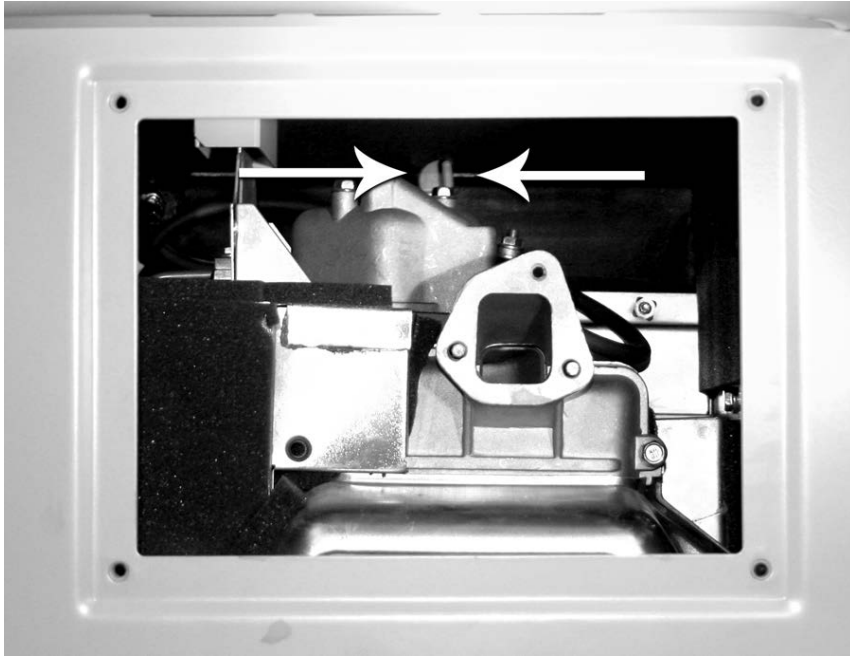

**Figure A** – Remove side panel, then remove air filter. Locate the “Red” Decompression Lever (Photo above shows it in the UP position). Press the lever down – this will hold the exhaust valve open. Replace the air filter assembly. Start the engine. You will notice that the spring loaded lever will automatically return to the UP position. (Also referred to as the decompression shaft assembly on the parts diagram.)



**Figure B** - Review the location of the AVR (Automatic Voltage Regulator. This item may eventually need to be replaced when they wear out.

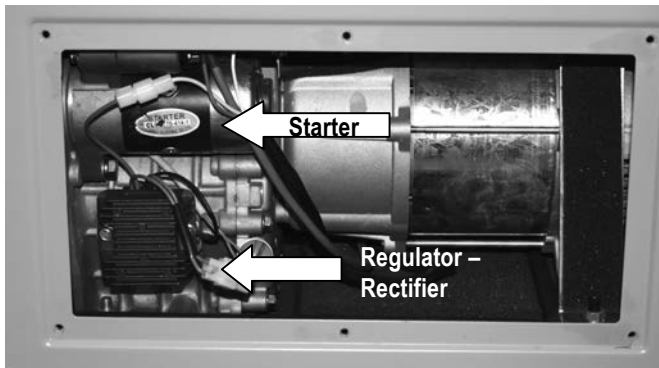

**Figure C** - Review the location of the rear access panel that has been removed. You can see the location of the starter and the regulator/rectifier for the 12V starting battery. The starter motor is located above the regulator/rectifier.

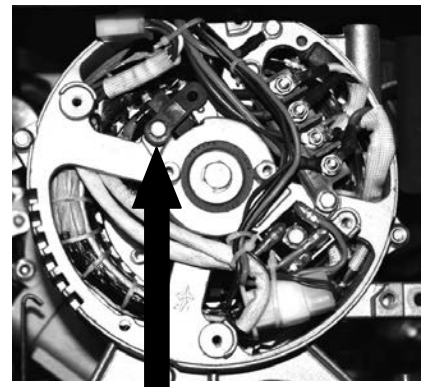

**Figure D** - Review the location of the Carbon Brushes. This item may eventually need to be replaced when they wear out.

GENSD7  
201504