

ITEM # SWTB36

Assembly Instructions

Max Weight Capacity 300 Lb

READ ALL INSTRUCTIONS AND WARNINGS BEFORE USING THIS PRODUCT.

This manual provides important information on proper operation & maintenance. Every effort has been made to ensure the accuracy of this manual. These instructions are not meant to cover every possible condition and situation that may occur. We reserve the right to change this product at any time without prior notice.

IF THERE IS ANY QUESTION ABOUT A CONDITION BEING SAFE OR UNSAFE, DO NOT USE THIS PRODUCT!

Questions? Problems? CALL CUSTOMER SERVICE FOR SERVICE, PARTS & TECHNICAL

SUPPORT. If you experience a problem, have questions or need parts for this product, visit our website

<http://www.amerihomebrand.com> or call Customer

Service at 1-636-532-9888, Monday-Friday,

8 AM - 4 PM Central Time, or email :

info@amerihomebrand.com. A copy of the

sales receipt is required.

KEEP MANUAL, SALES RECEIPT

& WARRANTY FOR FUTURE

REFERENCE

BARCODE

8 SCREWS " I "

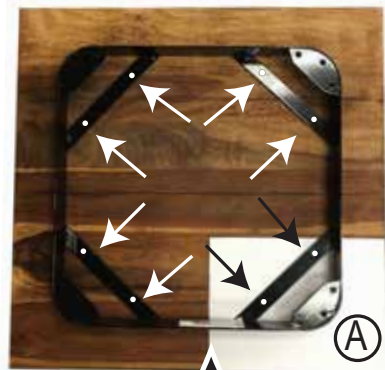

BARCODE

DRILLING INSTRUCTIONS

- 1) Place template in Corner (A) of table
- 2) Line up frame with template
- 3) Use a pencil to mark all holes
- 4) Remove template and drill holes

EDGE ▼

Drill Here

Drill Here

3 1/8"

E
D
G
E

TWO BOLTS "

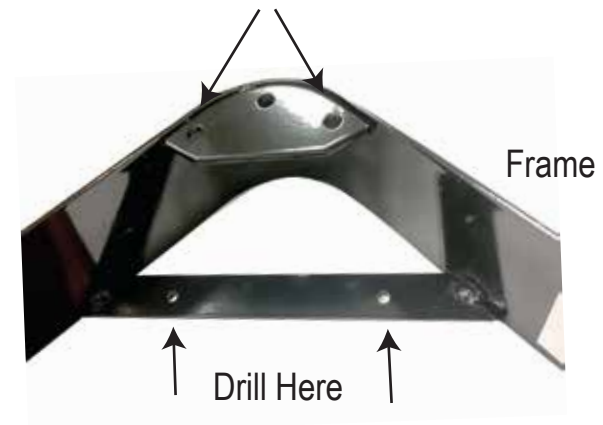

CORNER



STICKER

HARDWARE Identify and locate all hardware components listed below.

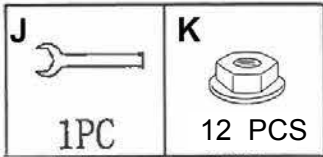
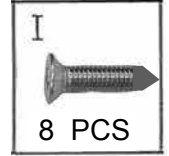
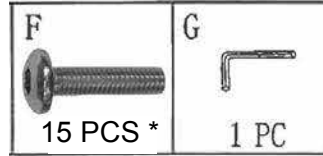
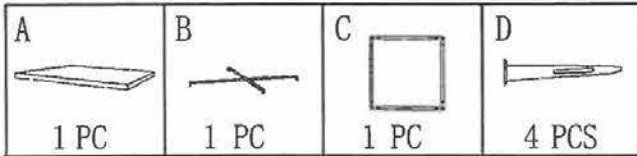

(* 2 pieces are extra)

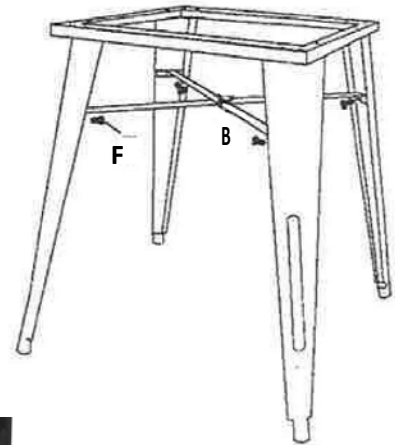
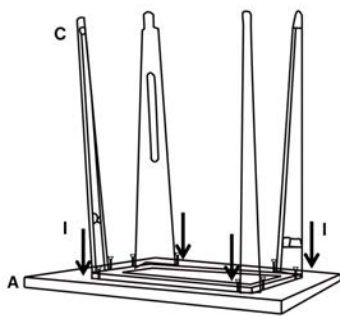

1. Attach each Table Leg (D) to Table Top (A) using 8 pieces medium screws (I).

2. Attach 1 piece X--support (B) using 4 pieces bolts (F).

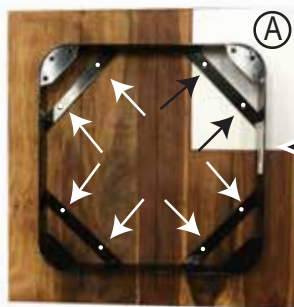

BARCODE

3. Attach each Table Leg (D) to Table Top Frame (C) using 8 pieces bolts (F).

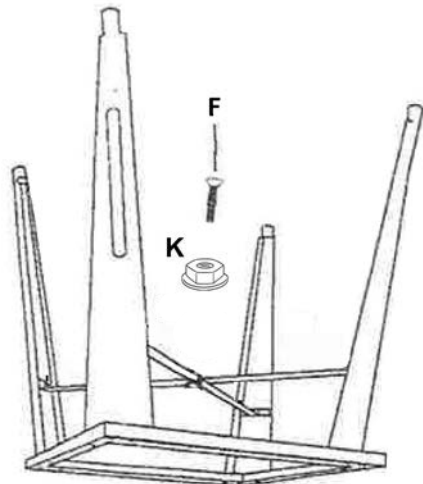

4. Attach X--support (B) using 1 piece screw (F) and nut (K).

5. When all pieces are attached, tighten each screw securely.