

HTMULT

Multi-Use Truck Rack

Assembly & Operating Instructions



READ ALL INSTRUCTIONS AND WARNINGS BEFORE USING THIS PRODUCT.

This manual provides important information on proper operation and maintenance. Every effort has been made to ensure the accuracy of this manual. We reserve the right to change this product at any time without prior notice.

STOP! DO NOT RETURN THIS PRODUCT TO THE RETAILER.

Questions? Problems? CONTACT CUSTOMER SERVICE.

If you experience a problem or need parts for this product, visit our website <http://www.buffalotools.com> or call our customer help line at **1-888-287-6981, Monday-Friday, 8 AM - 4 PM Central Time**. A copy of the sales receipt is required.

Multi-Use Truck Rack HTMULT Assembly and Operating Instructions

Verify that you have received the hardware and parts in the correct quantities as shown below and on the following page.

Hardware

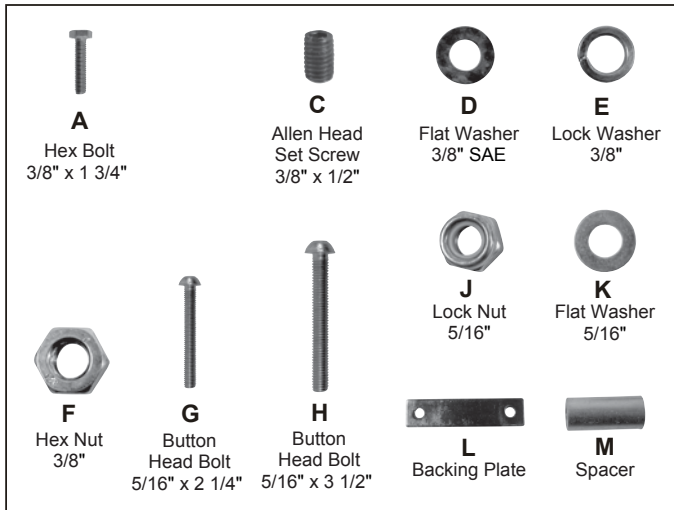

Parts

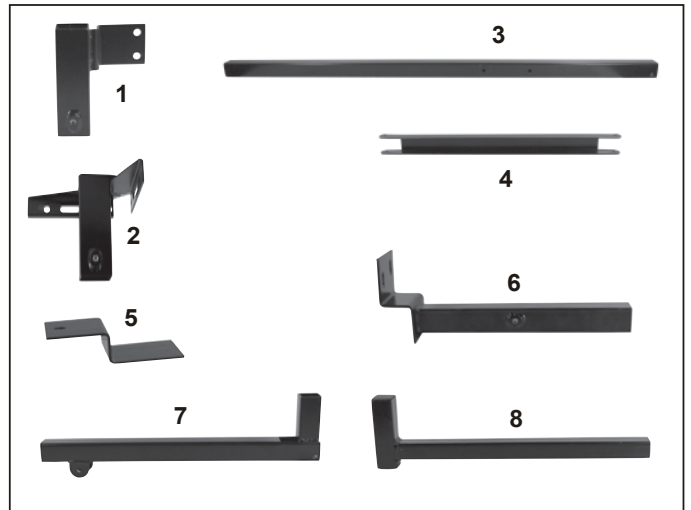

Hardware List

Item No.	Description	Quantity	Remarks
A	Hex Bolt: 3/8" x 1 3/4"	10	
C	Allen Head Set Screw: 3/8" x 1/2"	4	
D	Flat Washer: 3/8" SAE	18	
E	Lock Washer: 3/8"	10	
F	Hex Nut: 3/8"	8	
G	Button Head Bolt: 5/16" x 2 1/4"	4	
H	Button Head Bolt: 5/16" x 2 1/2"	2	
J	Lock Nut: 5/16"	6	
K	Flat Washer: 5/16"	12	
L	Backing Plate	1	
M	Spacer	2	

Parts List

Item No.	Description	Quantity	Remarks
1	Rear Upright Support Bracket	1	
2	Front Upright Support Bracket	1	
3	Upright	2	
4	Vertical Support Arm	2	
5	Ladder Stop	1	
6	Upright Support	2	
7	Horizontal Cross Arm	2	
8	Adjustable Arm	2	

Note: A Wrench and an Allen Wrench (not included) are tools required for installation.

WARNING: This product contains chemicals known to the State of California to cause cancer and birth defects or other reproductive harm.

Do not exceed 250 lb. weight capacity distributed evenly across both frames. Be aware of dynamic loading! Load movement could cause excess load, causing product failure. Strap ladder securely to rack. When expanding the Arm, leave approximately 2.5" of the tube in the frame.

Choose the left or right side to mount the Multi-Use Truck Rack. The Front Upright Support Bracket (2) will be bolted to the front bulkhead with one bolt on each side of the upright section and one bolt in the side stake pocket of the truck bed. The height of the Front Upright Support Bracket should allow the backing plate to be drawn tightly against the flat surface of the sheet metal of the bulkhead of the truck (FIG 1).

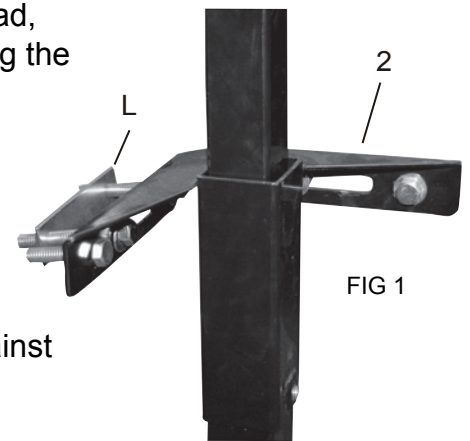

Step 1

Ensure that the Backing Plate (L) is level and mark the drill spots through the two holes of the Backing Plate. Drill ONLY two holes in the front bulkhead and ensure that those two holes align with the holes in the Backing Plate. Drill one hole near the center of the stake pocket.

Step 2

Insert the Upright Support (6) into the top of the Front Upright Support Bracket (FIG 2). Set them into position in the truck bed. If there are ribs on the floor of the truck bed, ensure that the foot of the Upright Support is set securely on a rib. It may be necessary to reinsert the Upright Support into the Front Upright Support Bracket in 90 degree increments to find a secure position.

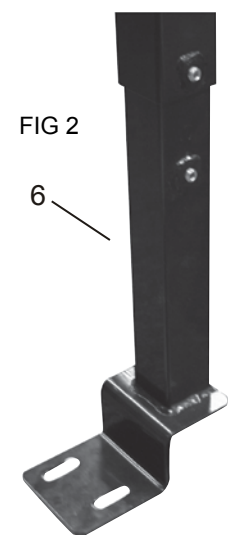

Be certain there are no obstructions underneath the foot plate.

Step 3

With the Upright Support inserted, attach the Front Upright Support Bracket (2) at the front of the truck bed using 3 bolts (A), 3 washers (D), and 1 Backing Plate (L). Position the foot so that the Upright Support is plumb. Mark the two drill spots in the truck bed through the two holes of the foot and drill. Attach the foot of the Upright Support to the truck bed using 2 bolts (A), 2 washers (D), 2 lock washers (E), and 2 hex nuts (F).

The Rear Upright Support Bracket (1) will be bolted to the vertical inside or forward face of the inner bed wall around the rear stake pocket.

Step 4

With the second Upright Support (6) inserted into the Rear Upright Support Bracket (1) (FIG 3) and set plumb into the truck bed with secure footing, position the Rear Upright Support Bracket so that the flange holes are near the center of the stake pocket as high as possible to allow the ends of the bolts and nuts to be accessible. Mark the two drill spots on the inner bed wall at the stake pocket through the two holes of the bracket flange and drill.

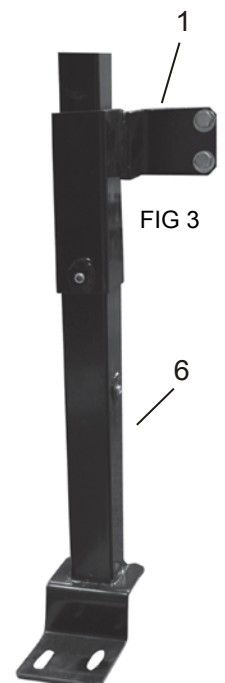

Step 5

With the Upright Support inserted, attach the Rear Upright Support Bracket using 2 bolts (A), 2 washers (D), 2 lock washers (E), and 2 nuts (F). With the foot of the Upright Support (6) plumb, mark and drill two holes in the truck bed. Attach the foot to the truck bed using 2 bolts (A), 2 washers (D), 2 lock washers (E), and 2 nuts (F).

Step 6

Assemble the upper arm (FIG 4) using button head bolts (G), flat washers (K) and lock nuts (J). Use bolt (H) to attach the Ladder Stop (5), with the Spacer (M) in the gap of the Horizontal Cross Arm (7) (FIG 5). Insert the Adjustable Arm (8) into the Horizontal Cross Arm (7) and adjust to the desired width. Secure it using set screws (C). Insert the Uprights (3) into the Upright Supports (6). Secure using set screws (C).

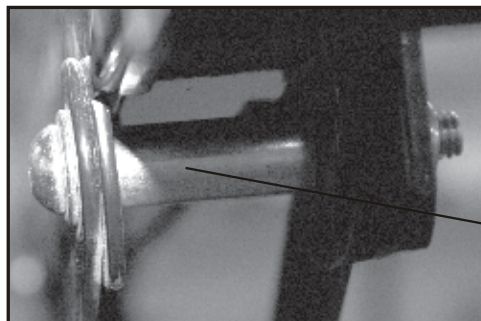
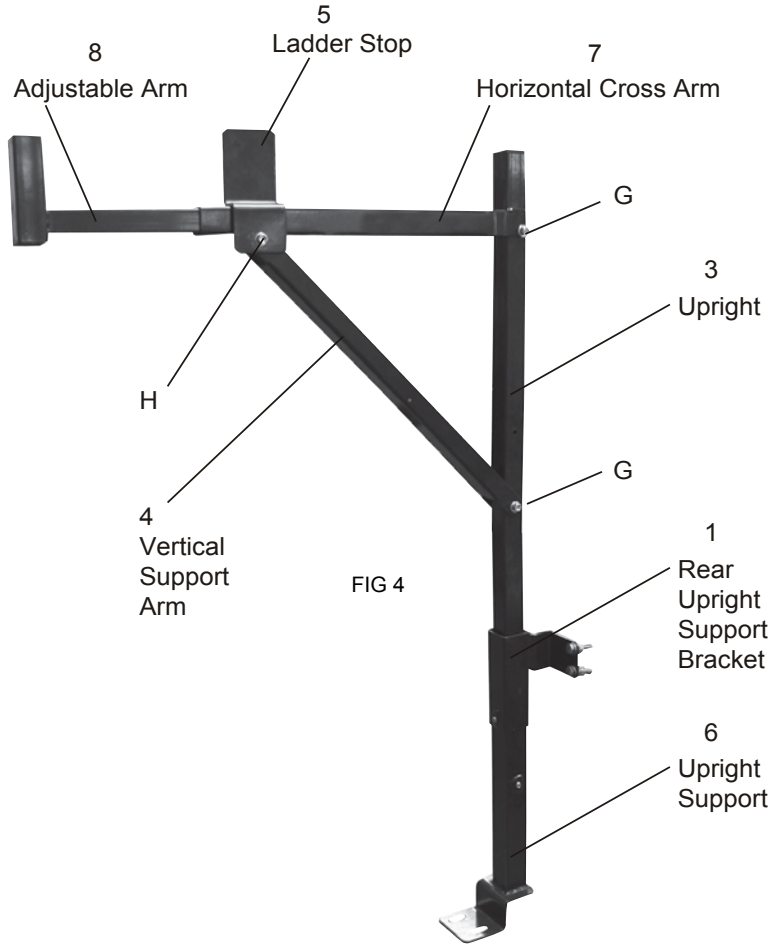

FIG 5



Note: Height is adjustable, from inside floor of bed to support arm. Height ranges from 48 Inches to 54 Inches.

Width is adjustable. Adjustable Arm (8) adjusts from 19 Inches to 32 Inches.

Length is dependant upon length of truck bed. One piece mounts on front of bed, one pieces mounts on back of bed.

Step 7

Tighten all attachments.

The Multi-Use Truck Rack is now ready for use.

WARNING: DO NOT EXCEED 250 LB. MAXIMUM LOAD CAPACITY.