

HTCARG

Cargo Truck Rack

Assembly & Operating Instructions



READ ALL INSTRUCTIONS AND WARNINGS BEFORE USING THIS PRODUCT.

This manual provides important information on proper operation and maintenance. Every effort has been made to ensure the accuracy of this manual. We reserve the right to change this product at any time without prior notice.

STOP! DO NOT RETURN THIS PRODUCT TO THE RETAILER.

Questions? Problems? CONTACT CUSTOMER SERVICE.

If you experience a problem or need parts for this product, visit our website <http://www.buffalotools.com> or call our customer help line at **1-888-287-6981, Monday-Friday, 8 AM - 4 PM Central Time**. A copy of the sales receipt is required.

Cargo Truck Rack HTCARG Assembly and Operating Instructions

Adjustable Width Crossbar Height Measures 28" From Bed Of Truck

Adjustable Width Measures 52 1/2" to 75" Wide

Verify that you have received the hardware and parts in the correct quantities as shown below.

Hardware



Parts

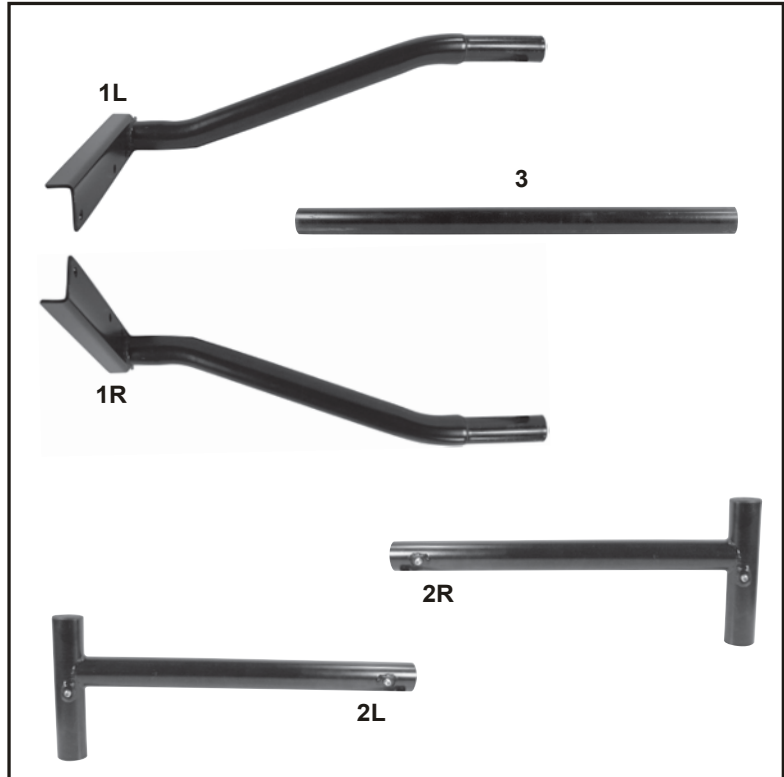

Hardware List

Item No.	Description	Quantity	Remarks
A	Hex Bolt: M10 x 45	8	
B	Flat Washer: M10	16	
C	Lock Nut: M10	8	
D	Allen Head Set Screw: M10 x 15	8	
E	Hex Bolt: M8x 65	4	
F	Flat Washer : M8	8	
G	Lock Nut: M8	4	

Note: A Wrench and an Allen Wrench (not included) are tools required for installation.

Parts List

Item No.	Description	Quantity	Remarks
1L	Left Upright	2	
1R	Right Upright	2	
2L	Left Crossbrace	2	
2R	Right Crossbrace	2	
3	Crossbrace Extension	2	

Step 1

Position the front Mounting Plate of the Upright leg as close to the cab as possible. Locate the pre-drilled hole in the footplate that is furthest from the leg and drill a 3/8" hole through the truck's bed rail. (FIG 1) A second hole for a bolt must be drilled through both the footplate and the truck's bed rail as close as possible to the front leg without sacrificing access to the bolt underneath the truck's bed rail. This bolt must be accessible in order to put on the washer and nut. Attach the footplate to the truck using bolts (A), washers (B) and nuts (C).

Repeat Step 1 as you position the remaining Upright leg for this section.

DO NOT over tighten any bolts.

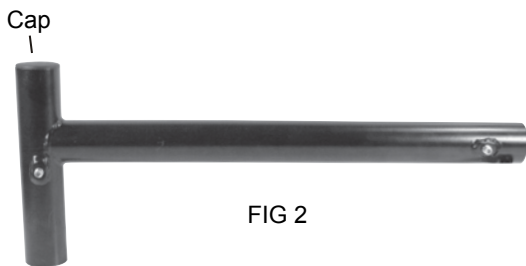
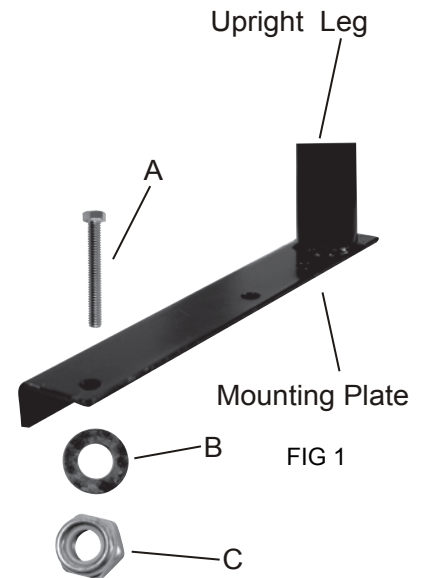

Step 2

Set the rack to the high (FIG 2) or low (FIG 3) position, whichever is best for the cargo and the truck, by flipping the Crossbrace. For bowed canoes, the high position is recommended. If you choose to flip the Crossbrace, you will have to remove and replace the Caps.

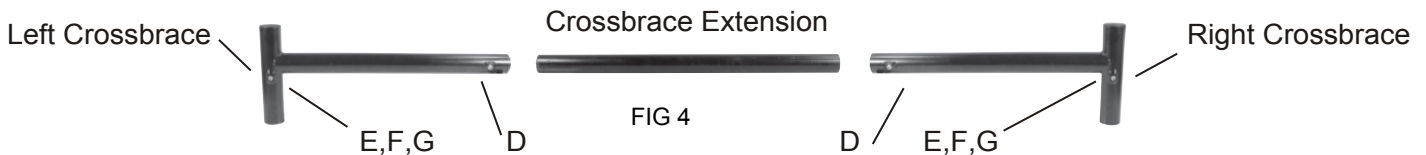

Step 3

Secure the Crossbrace to each Upright leg with the included Hex Bolt M8x65 (E), Flat Washer M8 (F), and Lock Nut M8 (G). Insert the Crossbrace Extension (FIG 4) into each Crossbrace and set the assembly on top of the Upright legs. Secure the Crossbrace Extension with Allen Head Set Screws (D).

To install the rear portion of the Cargo Truck Rack on the truck bed, repeat the above steps. Before drilling the mounting plate, ensure that the plate does not overhang or interfere with the tail gate.

The Cargo Truck Rack is now ready for use.

Note: You may also use as a Single Front-Mounted rack to support long items in the bed (Fig 5).

WARNING: DO NOT EXCEED 500 LB. LOAD CAPACITY.

